

FLY BETTER

(The things you should have been taught when learning to fly.)

Book Three - Second Edition

The Art of Aerial Navigation

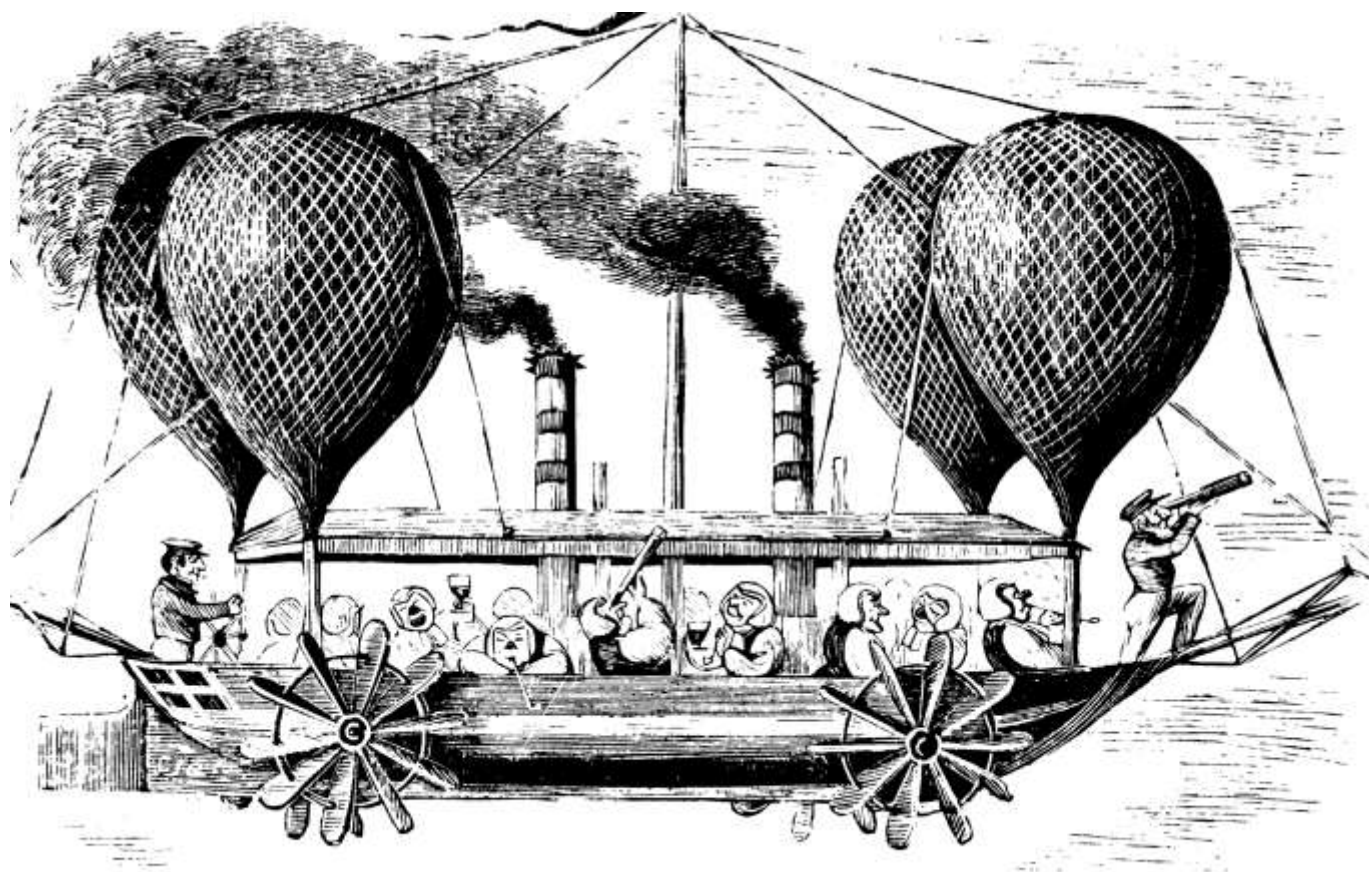

Transcripts of lectures about navigating by

Noel Kruse

Founder of the Sydney Aerobatic School.

"To a man of imagination, a map
is the key to adventure".

Sir Francis Chichester.

BOOK THREE CONTENTS

Preface	Page 4
Introduction	Page 6
Lesson 1. Navigation Logs	Page 9
Lesson 2. Time	Page 13
Lesson 3. Map Reading	Page 20
Lesson 4. Track Correcting	Page 22
Lesson 5. Track Crawling	Page 35
Lesson 6. Low Level Navigation	Page 36
Lesson 7. Lost Procedures	Page 37
Lesson 8. Fuel Consumption Graphs	Page 43
Lesson 9. Radio Aids to Visual Navigation	Page 54
Lesson 10. Area Navigation by Radio Aids	Page 72
Post Script	Page 84
Supplement: The Navigation Game	Page 86

This book has been released free of charge via the Internet for the benefit of aspiring aviators everywhere. It may be copied and its contents may be reproduced as required, but not for profit. It is requested that the authorship and origin of any part of this book reproduced out of context be acknowledged.

THE ART OF AERIAL NAVIGATION

PREFACE

With the modern Global Positioning System (GPS), extremely accurate navigation anywhere on the face of the Earth is available to everyone at the push of a button. GPS receivers can be hand held devices not much bigger than the size of a 'cell phone' and cost only a few hundred dollars. Indeed for a few dollars more a GPS/ Transmitter can be fitted into a dog collar or your teenage daughter's wrist watch so that you can track their every move!

With this technology available, why would anyone want to use the old labour intensive methods of navigating an aeroplane from A to D?

Many years ago I studied what could only be described as 'the ancient and arcane art' of Celestial Navigation. That is, navigation by reference to the Sun, Moon and Stars. Using a marine sextant and several volumes of books such as 'Celestial Almanacs' and 'Sight Reduction Tables' and half an hour of intense calculation, I would regularly 'plot' the position of Bankstown Airport (west of Sydney, Australia) to within 20 nautical miles of its actual location! (I used the trick of taking half the angular measurement between the Sun and its reflection in a puddle of water as its elevation as there was no precise horizon at the airport.)

I have never put these techniques to any practical use, but even now I can stand outside on a starry night and quickly gain a 'feel' for my approximate position on the Earth (give or take a few hundred miles) by just estimating the angles from a few key stars and constellations. It is a very satisfying feeling to just 'know' where you are without the use of any electronic aids or contrivances, save perhaps a watch. This is why I still navigate my aeroplane with only a map, a pencil, a compass and a watch. I do it for the sense of accomplishment I get and for the fun of it. Quite often it is the journey and not the destination which is the most satisfying part of flying from A to D.

Most aviation regulatory authorities still require training in basic pilot navigation skills to qualify for a Private Pilots Licence. For this I applaud them; however, the techniques taught by most flying schools to satisfy these requirements, tend to over-complicate the navigation process and remove any enjoyment the student pilot may get from it, thereby virtually guaranteeing that they will immediately rush out and purchase a GPS receiver upon graduation.

When I was a sixteen year old pilot 'wannabe' working as a 'Tarmac Hand' at the local aero club, I 'hitched' a ride in the back seat of the club's new Cessna 172, in which a student pilot was receiving navigation instruction. I recall that he seemed to spend a lot of time with his head 'inside' the cockpit writing down

numbers obtained from the constant manipulation of a circular device called a 'Navigation Computer'. I recall that we flew over a large town for which he was trying to calculate our arrival time, without him noticing its passage! It seemed to me, even then, that there was something wrong with the way he was being taught to navigate as I figured that visual navigation should involve mostly looking out the window at the world going by so that large towns shouldn't be missed, but hey, I was only 16 so what did I know? 50 years later I find that the teaching of pilot navigation techniques by most flying schools hasn't changed much. No wonder the graduates of these courses buy GPS units!

The Sabre, which I flew with the Royal Australian Air Force, was a single cockpit aeroplane with marginal longitudinal stability when carrying 'drop tanks' at high altitude (which was necessary if you wanted to go anywhere beyond one hour's flight time). Its only 'radio aid' was a 'steam age' ADF which preferred to point at thunderstorms, and was only useful for terminal guidance. The visual navigation task had to constantly be shared with the task of keeping the aeroplane under control, so this meant that the attitude had to be consistently monitored, and one hand was continually occupied holding that attitude. The navigation task could not be allowed to draw one's attention inside the cockpit for very long without the Sabre rapidly departing from level flight, so any manipulation of maps and pencils etc had to be done 'one handed'. To accomplish this task we were taught a very simple 'Graphic Navigation' technique, which could be done on a pilot's knee pad with one hand and without the use of navigation computers or any other 'gizmos' in the cockpit.

Twenty two years later, when the Sydney Aerobatic School became a fully fledged flying school, I tried to adapt this graphic navigation system to the slower speed and longer duration navigation profiles of light training aeroplanes, but found the time/distance graphs I created were so big that they would hardly fit in the cockpit, which of course rendered them unsuitable. I did, however, adapt the fuel flow graphs, and you will find instructions on the creation and use of these graphs in the lessons which follow.

Ultimately I devised a simplified version of the time/distance graph which didn't need a separate graph, but which recorded the data directly onto a properly prepared map and navigation log. This is the system that I and my staff taught successfully for the next 20 years, and I offer it to all students of pilot navigation and navigation instructors by way of this book.

I first wrote these lessons in booklet form for my students over 20 years ago, and I have reproduced them here virtually unaltered, including the original introduction. They are as relevant today as they were back then and detail a simple and reliable way of enjoying the art of aerial navigation.

PILOT NAVIGATION TECHNIQUES

INTRODUCTION

This booklet has been created to introduce, to students of pilot navigation, the simple techniques that will enable them to navigate anywhere over land in visual meteorological conditions (VMC) using only a watch, a map, a pencil, and a brain.

The fundamental principle of navigation is based on the simple premise that if you point an aircraft in the direction you want to go, and fly for the time you expect to take to get there, then at the end of that time you will probably be there! This is called “Ded Reckoning” (No, not ‘Dead’, ‘Ded’, short for “Deduced Reckoning” and often abbreviated to just ‘DR’). Pioneer trans oceanic aviators like Charles Lindbergh and Charles Kingsford-Smith, were experts at Ded Reckoning techniques and, whilst not used exclusively over land, where we can see where we are, the principle of holding an accurate heading for an accurate time still forms the basis of all navigation techniques, especially the ones detailed in these lessons.

If it weren't for certain errors creeping in to upset our planned flight, navigation would be as simple as holding a heading for a certain time. However, we can identify the types of errors that commonly occur and either correct or make allowances for them. The techniques detailed in these lessons have been designed to do that as simply as possible.

These errors fall into two general categories:

- A. Those we make ourselves.
- B. Those that are imposed upon us by circumstances.

Type A errors are:

1. Inaccurate pre-flight planning.
2. Inaccurate flying.
3. Inaccurate Map Reading.
4. Slips or goofs during the flight.

Type B errors are:

1. Wind velocity different from that expected.
2. Inaccurate maps.
3. Malfunctioning aircraft instrumentation.

To a certain extent B2 and B3 errors can be eliminated by proper pre-flight preparation and planning. So the major B error we have to contend with is caused by how much the actual wind enroute differs from the forecast wind.

Meteorological services, despite being 'streamlined' by the use of satellites and computer 'modeling' can still be inaccurate and unreliable. Area forecast wind velocities are an average of all reported wind velocities over areas of tens of thousands of square miles, and make no allowance for local effects which may prevail along your route. As a result we can say with absolute certainty that the wind you experience enroute will NOT be the wind forecast. Therefore, Type B1 errors are ALWAYS present.

Of the Type A errors we have to contend with, Type A1, flight planning errors can be further subdivided into pre-flight planning and in-flight planning errors.

Now I am assuming that you have already completed a Navigation Theory Course, and that you understand such things as: how to draw a line on a map, measure its true track angle and distance, and apply magnetic variation. You should also know how to operate a 'Dalton' type navigation computer to calculate heading, drift, ground speed and time interval. **If you have not done such a course, stop right here and go and do one before continuing.**

As a graduate of a Basic Navigation Theory course you should be equipped to carry out pre-flight planning with reasonable accuracy, so the A1 type error we are going to consider here is in-flight planning. That is, the error which inevitably occurs when we have to divert from our pre-flight plan and change course for some reason.

So the errors that we will be contending with the most in flight are, in order of common occurrence:

- B1. Wind variations.
- A2. Inaccurate flying.
- A3. Inaccurate Map Reading.
- A4. Silly mistakes.
- A1. In-flight planning.

Staying 'on top' of these five potential errors, in flight, is the primary task of the pilot navigator.

Before continuing further, it would be prudent to consider the environment in which the pilot navigator has to work. It is a far cry from the lecture room table at which you could spread out your maps and distribute pens, pencils, rulers, computers and cups of coffee. It is a noisy, cramped, little cockpit, situated behind an engine which demands attention. It is shared with a radio which also demands attention and is attached to an aeroplane which almost fully occupies the time and effort of at least one of your hands in preventing the whole contraption from rolling upside down and dumping you and your maps on the roof! The cockpit is also occupied by other people such as instructors or passengers who always interrupt you with some asinine comment when you are at a most crucial stage of your navigational calculations. There is no truth in the suggestion that pilot navigators are masochists, it just seems that way.

Because of all the competing demands on pilot navigators, it is essential that they order their priorities correctly, so here is your first "**GOLDEN RULE**":

AVIATE - NAVIGATE - COMMUNICATE

- in that order of priority. Never allow a lower priority function to interrupt or over-ride a higher one. Fly your aircraft first, then tend to the navigation task, then talk to someone about it.

Since our cockpit is a more difficult place to navigate from than a lecture room desk, it is to our advantage to be able to navigate with the minimum equipment. That is, a watch, a map, a pencil, a flight plan/log, and a brain.

So let's get down to it.

LESSON ONE

NAVIGATION LOGS

One of the great conveniences of air travel is the ability it gives us to get from one place to another quickly. This is possible not only because of the speed of modern aeroplanes, but their ability to travel in ‘straight lines’ between these places.

Whilst a light aeroplane may travel in straight lines, except in mountainous terrain, often the pilot will elect to fly via prominent features in order to simplify the navigation task. This means that the journey may be broken up into a number of short segments or ‘legs’ which may require the aeroplane to be headed in a slightly different direction on each leg. Indeed, during navigation training, the exercise may involve the student flying three or four different legs in quite different directions in order to finish up back where he/she started.

When planning such flights each leg must be planned individually because of the different effects that the prevailing wind will have on the aircraft’s track on each leg, and the different wind velocities which may be encountered at the different altitudes that may have to be flown. The data needed for this planning process includes:

- a. Airspeed, Indicated and True.
- b. Altitude and Temperature.
- c. Track direction and Distance.
- d. Wind Velocity.
- e. Magnetic Variation and Heading.
- f. Time Interval and Safe Endurance.

The Navigation Theory course that you have now done (or why are you reading this far?) has taught you how to manipulate all of this data to gain those ‘numbers’ that you need to conduct the flight. This whole process distills down to three important numbers for each leg; **altitude, heading and time interval**.

Before proceeding to the lessons about how to apply the various navigation techniques that I am going to teach you, I should warn you that these techniques involve some simple mental arithmetic ‘sums’, and therefore we need to record our ‘answers’ to these sums in a logical format somewhere in the cockpit. We record this information on a ‘Navigation Log’, (a ‘Log’, in this context, according to the Oxford Dictionary, is a “regularly maintained record of

progress”). So this first lesson is about ‘paperwork’! But this is necessary because examples of this Navigation Log are going to appear throughout the subsequent lessons, so it is a good idea to understand it first.

Usually the data and the calculations done pre-flight are recorded on some type of ‘Flight Planning’ proforma which contains little boxes where each piece of information can be recorded and which is very useful during this initial flight planning process. Unfortunately most pilots then take this piece of paper into the cockpit with them and use it as a Navigation Log, but using the Flight Planning Proforma as a Navigation Log has the potential of causing some of those silly errors and ‘goofs’ I spoke of earlier because of the clutter of too many numbers on the one piece of paper. Also the Flight Planning Proforma will not have enough ‘little boxes’ for us to record the enroute data we need during the navigation task.

The essential data (**altitude, heading and time interval**) should, once calculated, be transferred to a more ‘user friendly’ document for use in flight as a ‘Navigation Log’. The following is such a document.

NAVIGATION LOG

PLACE	ALT	HDG 1	HDG 2	HDG 3	TIME INT	ETA 1	ETA 2	ETA 3	ATA ATD
A									
↓	055	175			33				↓
D									
↓	050	060			28				↓
G									
↓	045	330			30				↓
A									

You will notice that in this document there are multiple rows and columns which form ‘boxes’ and in which the essential ‘data’ for the flight is recorded

before the flight commences. The other boxes are completed as the flight progresses. I will explain the use of some of these boxes here and the rest will be explained as we proceed through the various lessons to come.

The first box in the column headed ‘PLACE’ is where we put the name of the place from which we are departing, and below that the names of each place we are going to use as primary navigation features or turning points on the ‘way’ to our destination, and the last one is, of course, the name of the destination. We call these intermediate points, ‘waypoints’. In this example the flight is terminating back where it started so the last name is the same as the first. Each name should be written in each alternate ‘box’ down this column, and arrows placed in the boxes in between to indicate that we are ‘enroute’ between each place that the arrow links. These arrows also define the ‘enroute rows’ of the log, and this helps prevent the silly error of reading data from the wrong row.

The second column headed “ALT” is where we record the altitude we plan to fly at whilst enroute. This is usually recorded as a two or three digit number representing hundreds of feet and is recorded on the ‘enroute row’ between the appropriate waypoints as shown. (I have used three digits in these examples.)

The third column headed “HDG 1” is where the preplanned magnetic heading to be steered on this leg is recorded. It is also on the ‘enroute row’ of the log and is the initial heading we plan to steer from the place preceding it to the one following. Subsequent heading corrections (if required) are recorded in the “HDG 2” and “HDG 3” boxes next to it as the flight proceeds. The process by which we determine these heading corrections is detailed in Lesson Four.

The sixth column headed “TIME INT” is where the preplanned time interval for the leg is recorded. It is also on the ‘enroute row’ of the log and is the time we expect to take to get from the place preceding it to the place following. This time interval when added to the actual time of departure (ATD) will give the estimated time of arrival (ETA) at the next waypoint/destination. This ETA is entered in the “ETA 1” box next to the time interval (this is done once we are airborne and have departed A and recorded our ATD). Subsequent ETA revisions (if required) are recorded in the “ETA 2” and “ETA 3” boxes as the flight proceeds. The process by which we determine these ETA revisions is detailed in Lesson Two.

The final column is where the actual time of departure (ATD) or the actual time of arrival (ATA) at each waypoint/destination is recorded. This number is recorded on the row abeam the place name (the ‘place row’) of the departure point or waypoint/destination, not on the ‘enroute row’ as this number pertains to that place not the leg in between. (Another set of arrows remind you of this.) The following is another view of the same Navigation Log with these extra numbers included so that you can see how it all goes together. I have not

recorded any enroute corrections in this example as there are more lessons to come on how to do that.

NAVIGATION LOG

PLACE	ALT	HDG 1	HDG 2	HDG 3	TIME INT	ETA 1	ETA 2	ETA 3	ATA ATD
A									10
↓	055	175			33	43			↓
D									43
↓	050	060			28	11			↓
G									11
↓	045	330			30	41			↓
A									41

Many of my students have also used a 'highlighter' pen to highlight the "HDG1" and the "TIME INT" columns so that as the log fills with numbers they cannot be confused with the important ones. Also I have seen others draw a horizontal line through the entire 'enroute row' of numbers once that leg has been completed, again to avoid confusing this row with the next one. I will leave you to figure out a system like this that suits you after you have experienced your first goof!

LESSON TWO

TIME

Time is one of the two ‘basics’ of navigation. If a pilot navigator lacks an awareness of time, navigation will be impossible!

Many years ago a pilot took off from Parafield (South Australia) and headed for Mildura. The time interval for the flight was one hour. After four hours on the same heading, with fuel tanks almost empty and the sun about to set, the pilot made a landing in a paddock near a farm house. He was not far from Mudgee in eastern New South Wales! He had simply headed for Mildura and waited for it to appear ‘on the nose’; he pressed on with the thought “it should appear soon”. Incredible, yes, but instances of this nature abound, so here is your second "GOLDEN RULE"

ALWAYS have an accurate and reliable time piece in the cockpit or DON'T GO.

Enroute to his/her destination a pilot navigator should plan to fly via a series of ‘Way Points’ - places over which to pass on the ‘way’ to the destination, which are readily identifiable from the air. These way points should occur approximately every 30 minutes. If on a full ‘position reporting’ flight, Way Points can also be used as ‘Position Reporting Points’.

Let us imagine we are flying an aircraft at 120 knots (kts) ground speed (which is 2 nautical miles (nm) per minute), and proceeding from **A** to **D** as in Figure One. The distance from A to D is 60nm, therefore the time interval for the flight leg is 30 minutes, ($60 \div 2$).

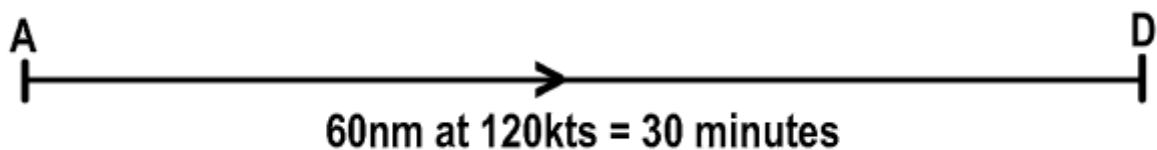

Figure One

As previously stated, if we head the aircraft accurately, at the end of 30 minutes we will be at ‘D’. But we know that errors are always present. If we have an unplanned 20kt headwind, then after 30 minutes we will still be 10nm short of ‘D’. To enable us to detect this error we should fix our position more often than every 30 minutes, because a 10nm error is too large an error to allow to accumulate.

Position fixing should be done, approximately, every 10 minutes. A 20kt wind error would have only caused about a 3nm position error in this time. An error which is small enough to be safe but large enough to indicate a general trend. Position fixing more frequently than this does not allow for the cumulative effect of minor errors to either cancel each other out or compound into a general trend.

To assist with this 10 minute fixing cycle our track should be marked with 'check points' at the 1/3 and 2/3 points. Let's label them **B** and **C** (Figure Two).

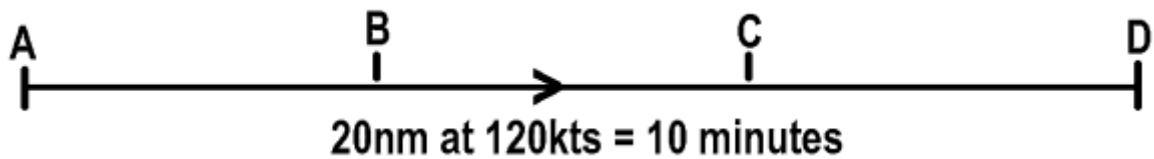

Figure Two

If our track from A to D is exactly 30 minutes long then B and C will divide it neatly into 10 minute intervals. In practice this rarely happens. When you plan your flight and have picked way points as close to 60nm apart as you can, divide the track into thirds. NOT 10 minute marks, but THIRDS. As we will not know our groundspeed at this stage we cannot be sure where 10 minutes will be anyway. If you are flying a leg of 40nm or less then divide it in half. I reiterate, our fixing cycle is at approximately 10 minute intervals so dividing the leg in this way will ensure that we have a reasonable fixing cycle and will make our in-flight mental arithmetic easy.

The first ingredient in fixing our position is to know what time to expect the check point to appear, so our ETA at each of these points (B, C & D) should be calculated and noted.

Example: Departed A on the hour

Time interval to D = 30 minutes

Therefore ETA D = Time 30

ETA B = Time 10

ETA C = Time 20

Note ETA D is calculated first as this is the time given in our position report information at A and recorded in our Navigation Log. ETA's for B and C are recorded on the map next to B and C respectively, as shown in Figure Three.

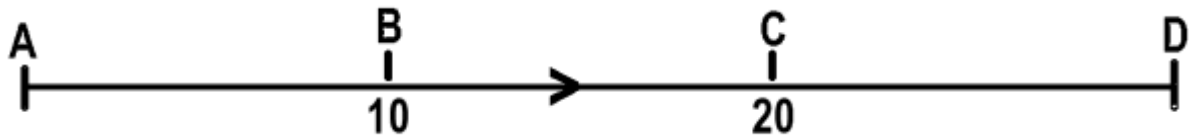

Figure Three

If subsequently we arrive at B at time 12, then we are already 2 minutes late. This means we will be 4 minutes late at C and 6 minutes late at D. So;

$$\text{ETA C} = 24$$

$$\text{ETA D} = 36$$

If the conditions which caused the error continue, we will arrive at C and D at our revised ETA's. Note that we did not recalculate the wind to amend our ETA's, we were working directly in time. The actual wind does not matter, only its effects do. Let's take a more realistic example:

Departure A at time 12

Time interval A to D = 33 minutes

Therefore: ETA D = 45

$$\text{ETA B} = 23$$

$$\text{ETA C} = 34$$

Arrive B at time 22 (1 minute early)

Therefore revised ETA C = 32 (2 min early)

revised ETA D = 42 (3 min early)

As a general rule whatever the time error is at the 'one third' point, it will be double at the 'two-thirds' point and triple at the 'three thirds' point, which is simple mental arithmetic.

What if the errors vary? In the previous example we expect to arrive at C at time 32 (revised ETA). What if we arrive there at 30, a further 2 minutes early? What is our ETA at D now?

Simple: Since we are now half way between points B and D the further 2 minutes early at C becomes a further 4 minutes early at D. Therefore ETA D = Time 38.

When the sums give you answers in fractions of minutes, round them out to the nearest minute.

Why do we need to try to be so accurate with our time estimates? Because time is the first ingredient in fixing our position by map reading. We need to have an idea of where we are to within a few miles (DR position) to be able to relate our map to the ground. More of that later. Another reason is that when operating on full reporting procedures the 'Flight Service Operator' (or whatever he/she is called in your country) will expect to hear from you within 2 minutes of your ETA. If you are running late, but have not advised her of your revised ETA, she will be calling you and interrupting you just when you are looking for your destination, a distraction you can avoid by advising ETA changes as they are determined at each check point.

What about the paperwork to help us keep track of these timing changes? For this we use the Navigation Log described in the previous lesson and shown here in Figure Three. The five columns marked; TIME, ETA1, ETA2, ETA3 and ATA/ATD are the ones that concern us here. (The use of the HDG columns will be dealt with in Lesson 4.)

So, using the preceding example; upon departing 'A' note the ATD in the ATA/ATD column and on the 'place row' abeam 'A' (time 12), add to it the TIME INT to 'D' (33 Minutes) and record this time in the ETA 1 column on the 'enroute row' of the Log (time 45), this is the first estimate for the arrival time at 'D'. (Figure Four).

PLACE	ALT	HDG 1	HDG 2	HDG 3	TIME INT	ETA 1	ETA 2	ETA 3	ATA ATD
A									12
↓	040	090			33	45			↓
D									

Figure Four

Then calculate the ETA's for checkpoints B and C and note them on the map near each check point (Figure Five).

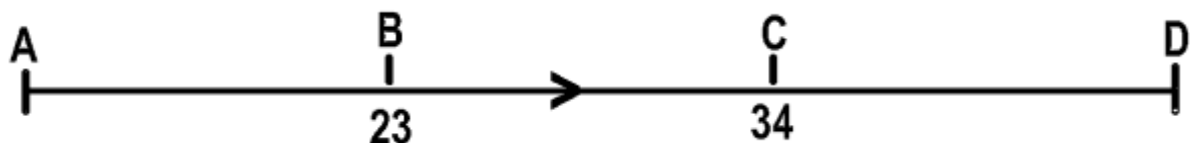

Figure Five

On arrival at checkpoint B, one minute early, the ETA for 'D' is recalculated and recorded in the ETA 2 column on the 'enroute row' (time 42), this is the second estimate for the arrival time at 'D', (Figure Six).

PLACE	ALT	HDG 1	HDG 2	HDG 3	TIME INT	ETA 1	ETA 2	ETA 3	ATA ATD
A									12
↓	040	090			33	45	42		↓
D									

Figure Six

Then update the ETA for checkpoint C and note it on the map. (Figure Seven).

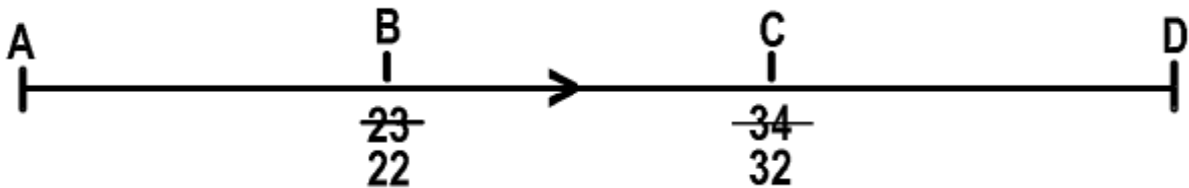

Figure Seven

On arrival at checkpoint C (a further 2 minutes early) the ETA for 'D' is recalculated once more and recorded in the ETA 3 column of the log (time 38). This is the final estimate for arrival at 'D', (Figure Eight).

PLACE	ALT	HDG 1	HDG 2	HDG 3	TIME INT	ETA 1	ETA 2	ETA 3	ATA ATD
A									12
↓	040	090			33	45	42	38	↓
D									

Figure Eight

Finally, upon arrival at 'D' the actual time of arrival (time 38) is recorded in the ATA/ATD column on the 'place row' above 'D' (Figure Nine) and the procedure is started all over again for the next leg.

PLACE	ALT	HDG 1	HDG 2	HDG 3	TIME INT	ETA 1	ETA 2	ETA 3	ATA ATD
A									12
↓	040	090			33	45	42	38	↓
D									38

Figure Nine

With a little practice you will be able to estimate your time of arrival at your way point/destination within +/- 2 minutes every time.

I recommend that even if a timing correction is not necessary at a particular checkpoint, the unrevised time be recorded in the appropriate ETA box to avoid any confusion caused by having empty boxes on the enroute row.

ONE OFF TIMING VARIATIONS

When considering the problem of ETA updating we have to assume that the errors noted at B will be cumulative over the remainder of the leg to D. There is one thing that we do that can cause non-cumulative timing errors and that is climbing. In a climb an aircraft is flying slower than in the cruise. Light aircraft usually climb at approximately 2/3 of their cruise speed. This slower speed will cause us to be late at B, but once we have leveled off and accelerated to cruise speed, this error will not accumulate. How do we allow for this? Simple, plan the leg as if there were no climbs and then add 30 seconds to the time interval to the first check point for each 1000ft of climb. So a total climb of 5000ft will add 2½ minutes on to our time interval to check point 'B' and onto the destination ETA.

It is of course possible to flight plan for the climb, provided it is a straight climb and not a 'stepped' climb. Light aircraft operating outside Controlled Airspace but departing from airfields in the vicinity of Primary Airports are usually required to 'step' climb to remain beneath the control area steps. So during the

first leg the aircraft may be making short climbs of 2000ft, (the usual CTA step altitude) every alternate 5 minutes or so which means that smaller increments of the total climb allowance will have to be added onto the time at each check point. An examination of the CTA structure and its relationship to your proposed route will reveal where each segment of the climb will occur.

So the general rule of thumb to allow for the climb is:

Make ‘one off’ corrections of 30 seconds per 1000ft of climb when calculating the ETA’s for check points and Way Points.

If you have an aeroplane which is powerful enough and ‘slippery’ enough to be able to sustain cruising speeds 10% or more faster than normal cruise speed for extended periods then it is possible to maintain your original time to destination rather than be at the mercy of the wayward wind. Obviously if you arrive late at a check point you are going to have to go faster to ‘make up’ time, but how fast and for how long. Here is the simple ‘formula’ that low level strike pilots use to correct for time late or early at check points to maintain their time on target.

Adjust airspeed by 10% for 10 times the time late (or early).

So, if you are cruising along at 120kts and find that you are running 1 minute late at a check point, you will have to accelerate the aircraft to 132kts (10% faster) and maintain this increased airspeed for 10 minutes. This will bring you back to ‘on time’, then halve the speed correction to stay on time, that is, reduce speed to 126kts. At the next check point you may have to once again apply a similar correction, albeit smaller, but this should then give you a speed which will maintain your time for the rest of the leg (assuming the wind effect hasn’t changed).

Obviously if you arrive at your first check point early then the reverse of this procedure applies. That is, slow down. If your first correction was to speed up it may cause you to be a little ‘ahead of time’ at the second check point, so this reverse procedure also applies.

If you don’t have an aeroplane which can sustain the higher speeds required to utilize this technique you can at least use it to slow down if you are ‘running early’if you see a need.

LESSON THREE

MAP READING AND PINPOINTING

Map reading is the art of being able to relate the contours, colours and squiggles on a map to the real world passing beneath you, such that you can put your finger on the map and say with confidence, "I am here!" As previously stated, time is an essential ingredient in navigation, and it is the starting point of our map reading process.

If we expect to be at B at time 23, then a couple of minutes before this time we examine the map to identify those features we expect to be able to easily identify on the ground. We start with the large features surrounding the general area, such as mountains, lakes and coastlines, and then we look outside and identify these features. Then we examine the map again, and work our way to the smaller features closer to D, such as roads, creeks and buildings. Then we look outside again and find these features, then repeat this cycle once again, working our way to even smaller features until ultimately we locate our position. Since we should be within a few miles of where we expect to be when we start this process, this simple technique will locate our exact position quickly and accurately. A good flying instructor is essential in helping you to learn this process.

By the way, we always hold our map so that the track marked thereon is aligned with our flight path, otherwise orientation difficulties may arise.

So by cross referring map to ground, map to ground, a few times and working from large features to small, we will be able to locate our position on the map with pinpoint accuracy. Indeed this is the name of the mark we make on the map to record this position - a 'PINPOINT'. It is a dot (our position) surrounded by a circle (to help locate the dot easily), like so: 

So the third GOLDEN RULE is:

WATCH, TO MAP, TO GROUND

Determine where you should be on the map by time; seek suitable features on the map in your expected location; find them on the ground. Repeat steps 2 and 3 working from the 'big picture' to the small, to 'fine tune' your pinpoint. Then mark your pinpoint on the map and immediately mark the time next to it.

Example: ₂₂

Refer to Figure One. We have pinpointed ourselves at B at time 22. We can now recalculate our revised ETA's for C and D, and use these revised times to start the map reading and pinpointing process again.

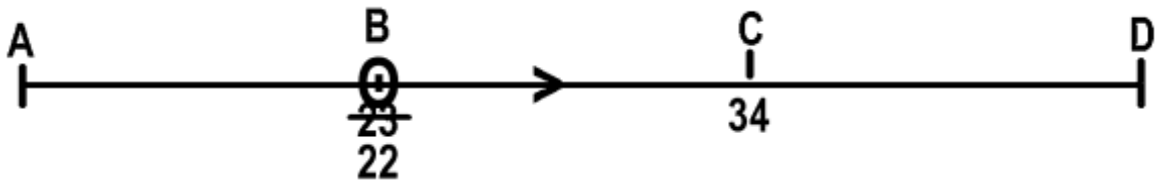

Figure One

We should attempt to pinpoint ourselves as close to our 1/3 (B) and 2/3 (C) check points as possible. Prior examination of the map will allow us to anticipate whether there is going to be suitable fixing features at our 1/3 and 2/3 points or whether a nearby feature is more suitable.

What if there were no suitable pinpointing features at checkpoint B, but just a short distance beyond there was an ideal feature? Simple; using a rule of thumb of 2 nautical miles per minute (120kts) estimate the ETA of the feature. Say the feature was about 4nm past B and since our original ETA B was 23, then the ETA of the feature is 25. If we arrive at the feature at 24 we reverse the rule of thumb and mark time 22 against B and continue our time calculations from there (Figure Two). The reverse would apply if the feature was before B. Note; even though our early arrival at B suggests a ground speed greater than 120kts, the use of 2 miles/minute over very short distances is close enough, especially when we round our times out to whole minutes anyway. Exercise caution, when using this rule of thumb beyond 3 minutes from your 1/3 or 2/3 as it may become too inaccurate.

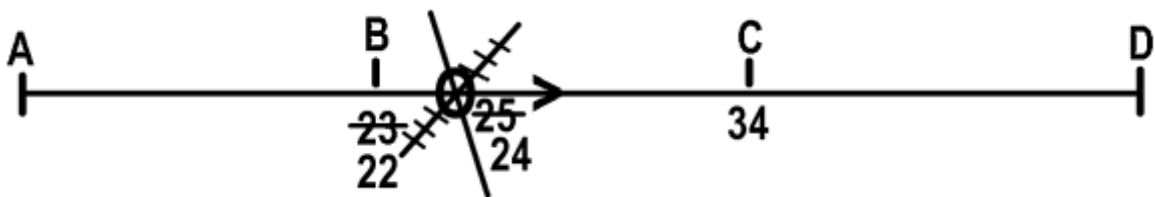

Figure Two

LESSON FOUR

TRACK CORRECTING

So far we have considered only errors which effect our ground speed and ETA's. If our errors cause us to be off track at our 1/3 and 2/3 points we must correct our heading to 'make good' our waypoint. Note that there is a fundamental difference in philosophy here. With ground speed errors we don't attempt to correct them, we just calculate their effect and amend our ETA. With track errors we must correct in order to get to where we want to go.

Our primary tool in calculating corrections is called the 'one in sixty rule'. What this means is that, one mile off track after traveling 60 miles subtends an angle of 1 degree at the starting point, (See Figure One). That is, our track has a one degree difference to that planned. 2 miles off track over the same distance subtends 2 degrees and so on, up to a maximum of 15 degrees. Beyond 15 degrees inaccuracies creep in.

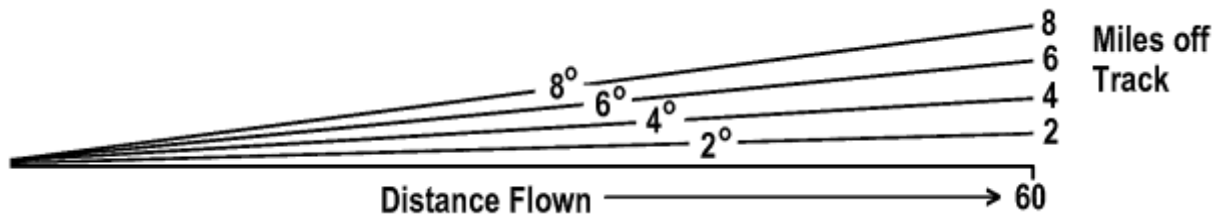

Figure One

Of course we don't need to go 60 miles before we can use the 1:60 rule, we can work out track angle errors for any distance by simple proportion as shown in Figure Two.

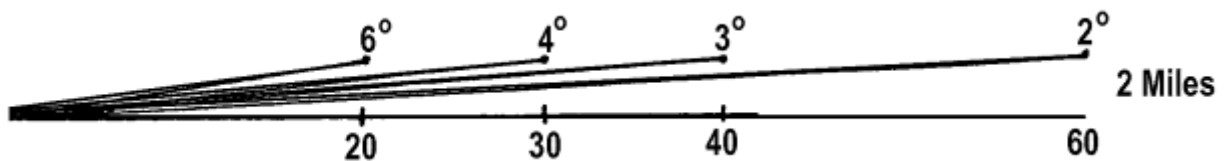

Figure Two

2 miles off in 20 = 6 degrees.

2 miles off in 30 = 4 degrees.

2 miles off in 40 = 3 degrees.

The simple mental arithmetic formula we use for this calculation is:

$$\frac{60}{\text{Distance run}} \times \text{Distance Off Track} = \text{ANGLE}$$

How do we use this formula, in our head, in flight? Start with the number 60 and divide it by the distance run, then multiply the answer by the distance off track.

So if we were 3 miles off track the formula would give us the following:

$$3 \text{ miles off in } 20 \text{ run} = 60/20 \times 3 = 9 \text{ degrees.}$$

$$3 \text{ miles off in } 30 \text{ run} = 60/30 \times 3 = 6 \text{ degrees.}$$

$$3 \text{ miles off in } 40 \text{ run} = 60/40 \times 3 = 4\frac{1}{2} \text{ degrees.}$$

Since we are using approximately 60 mile leg lengths, our 1/3 and 2/3 points occur at approximately 20 and 40 miles respectively. Approximately is good enough - there is no point in calculating fractions of angles when we are going to round them off anyway. So, if you have run 18 miles, call it 20, and if you have run 27 miles, call it 30. This makes the sums much easier and the answers will be good enough. Besides, I have yet to meet the pilot who can maintain heading ± 2 degrees for very long.

So how do we use this 1:60 'rule' to help us correct our track? Let's go back to high school geometry for a moment.

Theorem: The external angle of a triangle is equal to the sum of the two interior opposite angles. Refer to Figure Three.

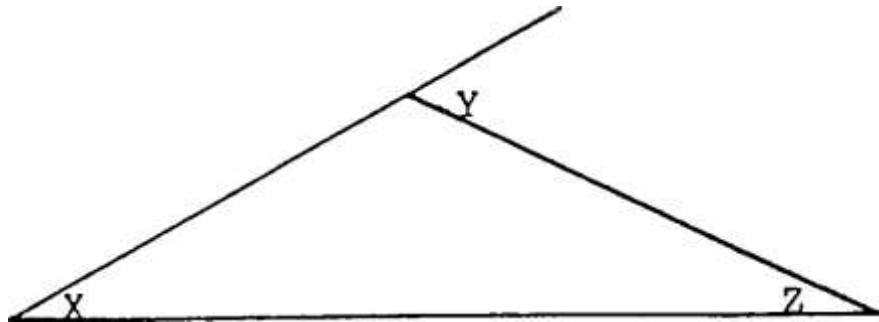

Figure Three

What this means is that angle Y equals the sum of angle X and Z, that is $Y = X + Z$. So what? Well, imagine you pinpoint yourself 2 miles left of track at B, how many degrees do you alter heading to get to D? Refer to Figure Four.

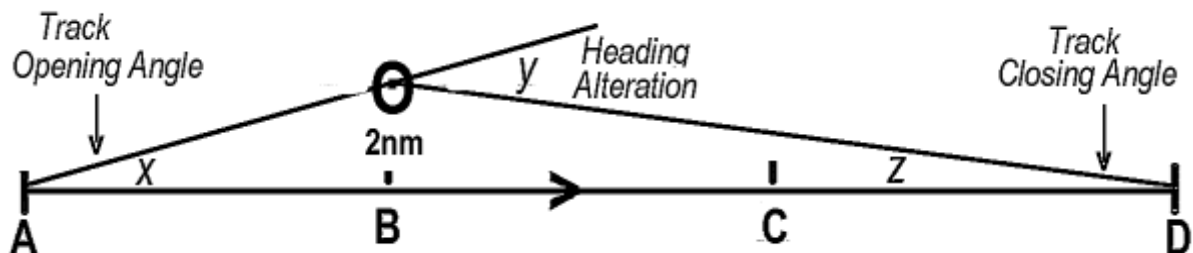

Figure Four

Angle X is called the track opening angle, Angle Z is called the track closing angle and Angle Y is the heading alteration angle to arrive at D.

So: $Y = X + Z$, Becomes: Heading Alteration = Opening angle + Closing angle.

How do we calculate the actual opening and closing angles? We use the 1:60 rule. So Figure Four becomes Figure Five as follows:

the opening angle is:

$$60/20 \times 2 = 6 \text{ degrees.}$$

and the closing angle is:

$$60/40 \times 2 = 3 \text{ degrees.}$$

Therefore the heading alteration is:

$$3 + 6 = 9 \text{ degrees.}$$

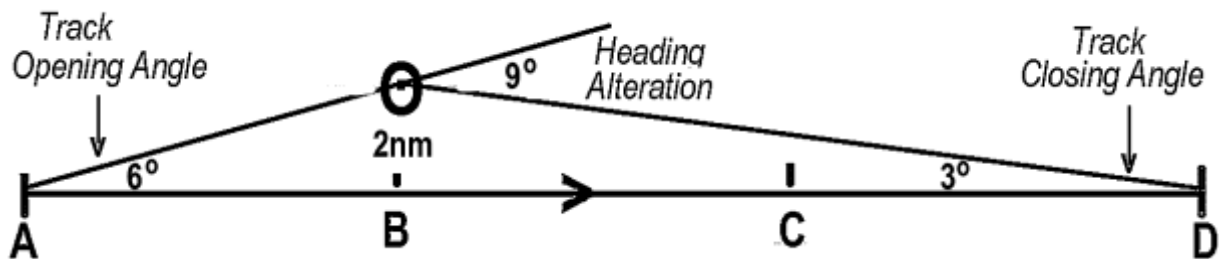

Figure Five

Also from Figure Five, you will notice that the closing angle is half the opening angle, because the distance to go is twice the distance gone so far. So rather than doing two sums, just calculate the opening angle and add 50% or, calculate the closing angle and multiply by three. Too easy.

Recall that I said previously, that if the track distance was 40 miles or less only use 'half way' points. In this case the calculation is even simpler, the opening and closing angles are the same, so calculate one of them and double it for your heading alteration.

Let's work an example of a 40nm total track distance; refer to Figure Six:

Distance off Track at B = 2 miles.

Therefore Opening Angle = $60/20 \times 2 = 6$ degrees.

Therefore Closing Angle = 6 degrees (Same as opening angle).

Therefore Heading Change = 12 degrees.

Obviously the direction of the heading change is toward our planned track.

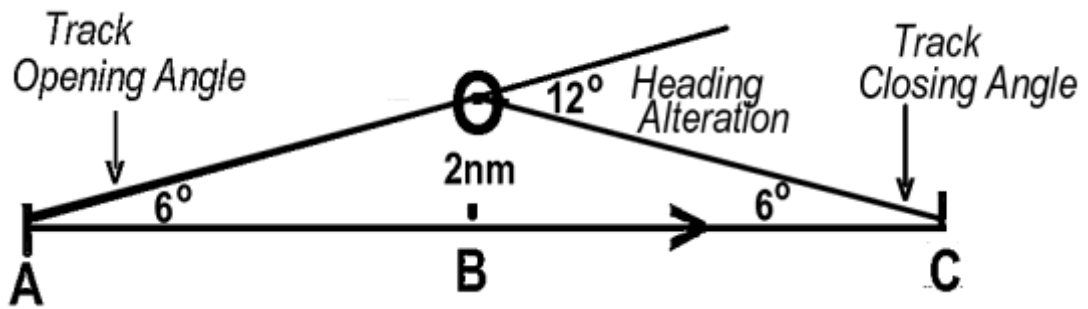

Figure Six

Go back to the 60nm track distance once again. If the conditions which caused the track error are consistent, then you should regain track at D, and pass abeam C half the distance off track that you were at B. Note that you are never actually back on your original track; however, you are sufficiently close for the line on your map to serve as a reference line to aid map reading to the next pinpoint. You may find it useful, having pinpointed yourself near B and having finished doing all of your track corrections and ETA updating sums, to sketch a light line parallel to your marked track and half your B position track error, abeam point C, just to remind you where you expect to be in approximately 10 minutes time. If we arrive abeam C at this distance no further heading corrections are necessary - you are on your way to D. (Figure Seven.)

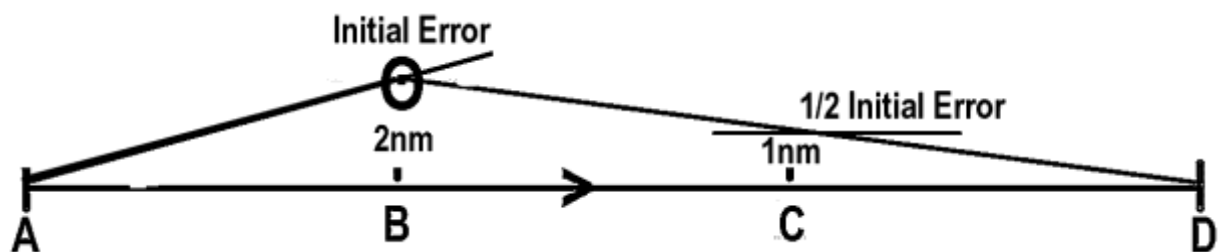

Figure Seven

What if upon reaching the vicinity of C we pinpoint ourselves in a position other than expected? No problem, since we had a positive fix at (or near) B, we can think and act as if that fix is our starting point and that we are flying a 40 mile (approximate) leg to D with C as our half way point along our new track..

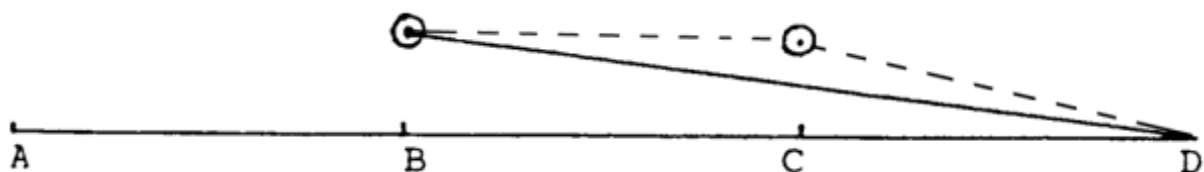

Figure Eight

Examine Figure Eight. We expected to pass abeam C with half the track error we had at B but in fact find we are further from C than this. Let's assume we were 2nm off track at B and have recalculated our heading to D as previously described. We would expect to pass abeam C, 1nm left. If we in fact pinpoint ourselves 2nm left of C then we are 1nm left of our revised track from B to D. We have flown 20 miles from B and have 20 miles to go, so our opening angle from B is 3 degrees and our closing angle is 3 degrees. Therefore we must alter heading a further 6 degrees (right) to get to D.

What if we find ourselves back on our original track at C. Can we relax and say "Oh well I made it back to track sooner than expected, I will just press on?" No we cannot, because if we do we will 'overshoot' the original track. Apart from being a useful orientation aid on our map our original track is irrelevant to these calculations, it is the distance from the revised track B - D that's important now.

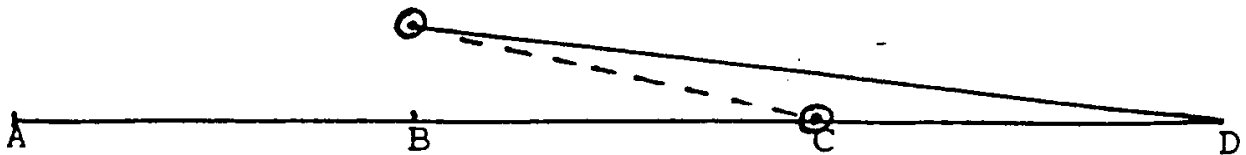

Figure Nine

Examine Figure Nine, we are back on original track but 1nm right of our revised track, so we must alter heading 6 degrees (left) to get to D. We will now be following the original line on our map, but steering a different heading to that originally planned, in order to maintain that track.

So we now have a method of regaining track at destination by correcting for track errors as they are observed. No need for recalculating wind velocities or drift angles or using a navigation computer in flight. It can all be done with a map, a pencil and a brain.

We now have two navigation tools at our disposal; one for correcting track and the other for correcting ETA; which do we use first? Well, since ETA updating is addressing the future it can wait a few moments. Any track error will continue to build, so track corrections should not wait; we do them first. Let's do one example to consolidate the two processes. Imagine we are flying from A to D.

Departure Data at A:

Heading to D = 090° and Time Interval to D = 30 minutes.

Depart A at Time 17, therefore:

Estimate D Time 47 (Recorded on the Nav Log.)

Estimate B Time 27 (Recorded on the Map.)

Estimate C Time 37 (Recorded on the Map.)

So our Navigation Log will look like this upon departure, (Figure Ten):

PLACE	ALT	HDG 1	HDG 2	HDG 3	TIME INT	ETA 1	ETA 2	ETA 3	ATA ATD
A									17
↓	050	090			30	47			↓
D									

Figure Ten

Upon arrival at checkpoint B.

Pinpoint 3 miles abeam B at time 29, (Figure Eleven).

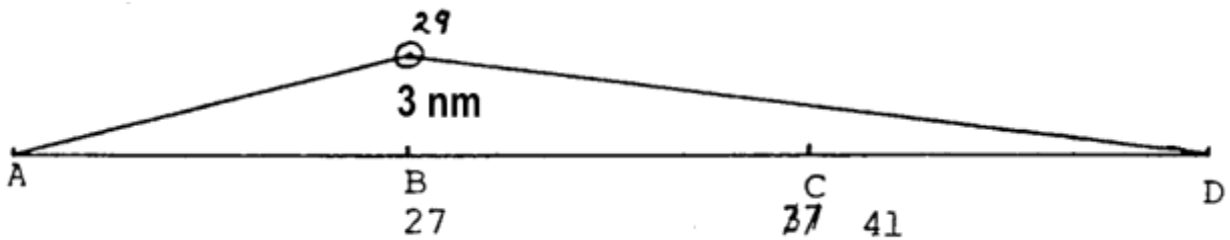

Figure Eleven

First, correct track: $60/20 \times 3 = 9$ degrees opening angle.

Plus: half of 9 degrees closing angle.

Therefore heading correction = $9 + 4\frac{1}{2} = 13\frac{1}{2}$, say 14 degrees right.

Therefore alter heading to 104° .

Second, update ETA's: 2 min late at 1/3rd way = 6 min late at D.

Therefore ETA D = 53 and ETA C = 41.

What if the first pinpoint was at a feature 4 miles before B? No problem, update your time at B by 2 minutes (2 miles/minute as previously discussed), and do your track correcting sums AS IF the pinpoint was abeam B. The difference in the heading alteration will be less than one degree; well within normal steering tolerances.

Departing checkpoint B our Navigation Log will now look like this, (Figure 12):

PLACE	ALT	HDG 1	HDG 2	HDG 3	TIME INT	ETA 1	ETA 2	ETA 3	ATA ATD
A									17
↓	050	090	104		30	47	53		↓
D									

Figure Twelve

Upon arrival at checkpoint C

Pinpoint 3 miles abeam C at time 40, (Figure Thirteen).

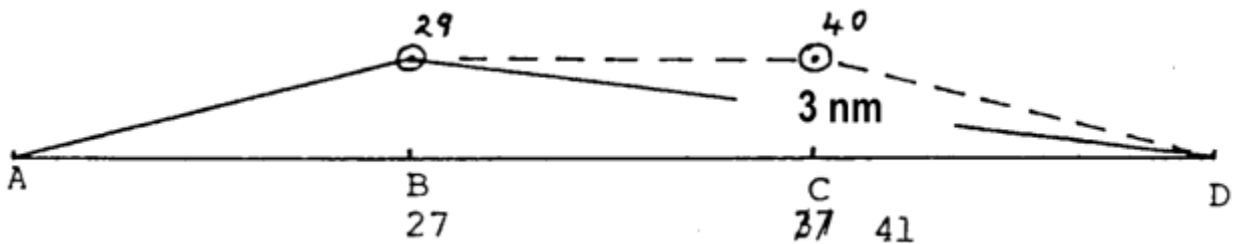

Figure Thirteen

First, correct track: Expected to be $1\frac{1}{2}$ miles left of original track,
Therefore $1\frac{1}{2}$ miles off revised track.

Opening angle: $60/20 \times 1\frac{1}{2} = 4\frac{1}{2}$ degrees.

Closing angle: Same.

Therefore heading correction: $4\frac{1}{2} + 4\frac{1}{2} = 9$ degrees right.

Therefore alter heading to 113° .

Second, update ETA: 1 min. early on revised estimate for C.

So, 2 min early on revised estimate for D,

Therefore ETA D = 51.

Departing checkpoint C our Navigation Log will now look like this, (Figure 14):

PLACE	ALT	HDG 1	HDG 2	HDG 3	TIME INT	ETA 1	ETA 2	ETA 3	ATA ATD
A									17
↓	050	090	104	113	30	47	53	51	↓
D									

Figure Fourteen

Finally we arrive at D at time 50 (nobody is perfect) and record that fact in the ATA/ATD column on the 'Place Row'. We then use the data from the next 'enroute row' to continue our journey.

Departing D our Navigation Log will now look like this, (Figure Fifteen):

PLACE	ALT	HDG 1	HDG 2	HDG 3	TIME INT	ETA 1	ETA 2	ETA 3	ATA ATD
A									17
↓	050	090	104	113	30	47	53	51	↓
D									50

Figure Fifteen

Even if a heading or timing correction is not necessary at a particular checkpoint, the unaltered heading and/or time should be recorded in the appropriate HDG and ETA boxes to avoid any confusion caused by having empty boxes on the enroute row.

At Annex A, I have detailed a mental checklist to help you through this procedure without omitting anything.

This track and time correcting method is so simple and reliable that it will make allowances, not only for forecast wind errors, but also flight planning errors. Indeed, provided you can guess your track to within about 15 degrees and mark

1/3 and 2/3 points on the track with reasonable accuracy, this method will compensate for any errors contained in your 'guesstimates' and the prevailing wind simultaneously. For example, if your planned track was 270° but you inadvertently transcribed 260° to your Log, or, because you were doing an in-flight diversion you guessed 260°, then at your 1/3 point you would be about 3½ nm left of track.

The track correcting method would immediately show you that you had a 10 degree opening angle, and would give you a heading correction of 15 degrees right. Your new heading would be 275° to make good destination. Regardless of the errors which caused the initial track deviation, the new heading of 275° is dead accurate.

Suppose you were unable to estimate your leg length accurately but could judge 1/3 and 2/3 points. By the time you reach the 1/3 point your final ETA at destination is handed to you, it is 3 times the time it took to get to the 1/3 point added to your departure time. By working directly in time like this you need never know exactly how far you have flown to B, but you know exactly what time you are going to get to D. But of course you can now work 'backwards' at 2nm per minute to determine the distance flown, and apply that to the 1:60 rule to calculate a revised heading if required. (So, your clock can also be regarded as your 'odometer'.)

This is the technique used for in-flight diversions or changes of track. Suppose, whilst flying along your planned track, you come upon a solid 'wall' of cloud which prevents you from proceeding further. You decide to divert to an alternate destination abeam your planned track, where you may find a way around the cloud or be able to land and wait for clearer weather.

The first thing to do is pinpoint your position and mark it on the map. Then turn toward your revised destination and guesstimate the heading to steer. Then sketch the new track as accurately as possible and mark a half way point (I am assuming we don't have to divert more than 40 miles off track.) If you can estimate the distance to travel you can roughly determine the ETA to the half way point. Once you have pinpointed yourself in the area of the half way point apply the track correcting and time correcting techniques - the resulting heading and ETA's will be as accurate as if you had pre-flight planned them.

For example, suppose we arrived at C at time 40 and decide to divert to 'E'. We turn onto our guesstimated heading toward E, draw the track and mark a half way point. On arriving at the area of the half way point we pinpoint our position and correct the heading by doubling the opening angle error. We then note the time interval and double it to gain an ETA for E. What could be simpler? Check out Figure Sixteen.

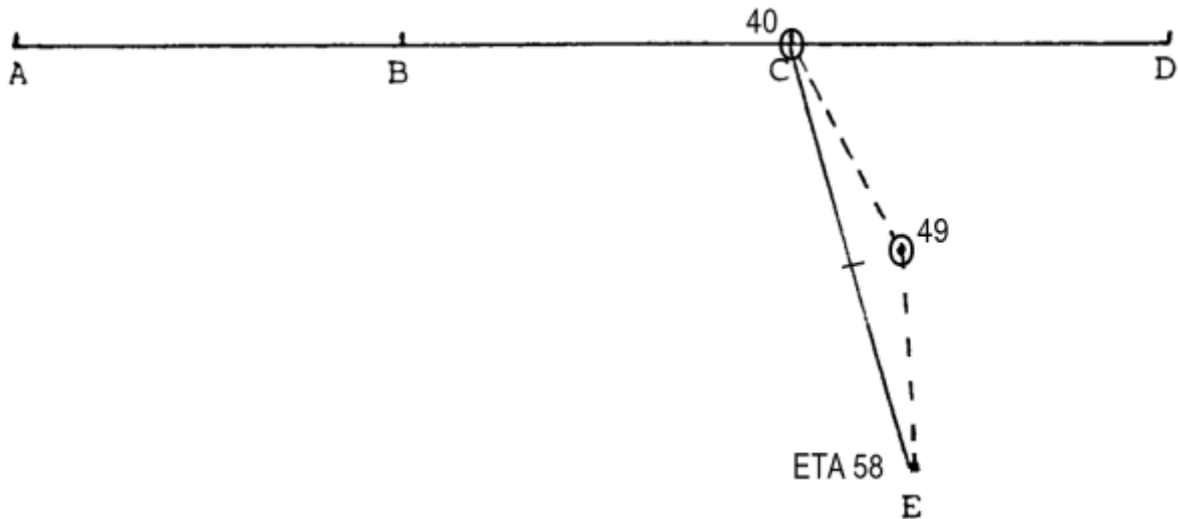

Figure Sixteen

To improve your ability to ‘guesstimate’ tracks and distances I suggest that during your initial pre-flight planning you guesstimate all of the tracks and distances for the flight and note them on a scrap of paper before you measure them using your protractors and scale rulers. You will be surprised how accurate you will become within a short time. You will also find that this will aid your general orientation for the flight and help prevent any silly measuring errors too.

There is a variation to this track correcting method which many aviators prefer to use. It uses the ‘short leg’ technique to regain track before destination on ‘long legs’. This method is often given the name “Double Error Method”. Using this method, instead of making a new track from B all the way to D, the opening angle at B is doubled which causes the aeroplane to regain track at C. Obviously upon arriving at C another heading alteration is required to prevent ‘overshooting’ the original track. This alteration is half the original correction back the other way. Examine Figure Seventeen.

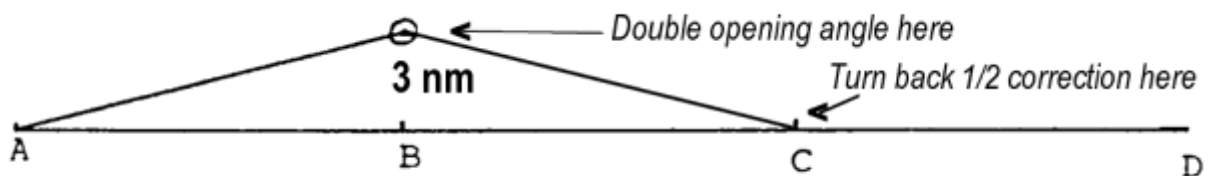

Figure Seventeen

In Figure 17, assume that the original heading was 090° . The pinpoint abeam B gives us an opening angle of 9° and by turning right by double that amount, to a heading of 108° the aircraft will regain the original track at C. Upon arriving at C the heading is altered back to the left by 9° to 099° . The 9° difference in this new heading compared to the original heading compensates for the unplanned drift which must be present. Heading 099° should now track the aeroplane to D.

Whilst this technique is initially simpler to use at B, it assumes that the aircraft will arrive back on track at C. If it doesn't, if there are further errors, the next correction is more complex and can be a bit 'messy'. Examine Figure Eighteen.

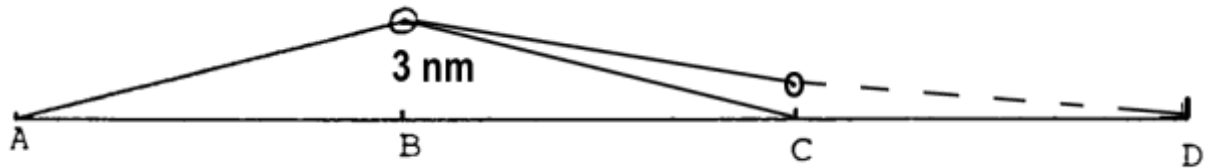

Figure Eighteen

If the pinpoint at C is one mile left then there is a further track error of 3° necessitating a heading alteration of 6° , but which way? At C we had planned to alter heading 9° left, but this new correction suggests a heading alteration of 6° right! So the final alteration is 3° left. Like I said, this is a bit messy, but you can decide which technique you prefer after you have trialed each of them.

I have used this technique on very long legs where I have divided the leg into quarters rather than the usual thirds. The aim is to regain track at C and then start the process all over again for the remaining two quarters.

To assist my students in practicing these track correcting and ETA updating techniques, I created a 'Navigation Game'. I have reproduced this game in the supplement at the end of this book.

A final note on mental arithmetic. When we were kids in school, and the teacher set us an arithmetic problem, we all got into the habit of looking down at the piece of paper we were working on whilst doing the sums. You don't have that luxury in an aeroplane as it is constantly demanding your attention to its attitude 'outside'. Whilst there is a bit of mental arithmetic involved in the navigation techniques detailed herein, each individual 'sum' is quite simple and can be done in your head without looking down at your navigation log. Once the answer has been calculated it only takes a couple of seconds to look down and record it. So you need to practice simple mental arithmetic whilst looking straight ahead and doing something else. I recommend practicing this technique by adding up the numbers on the registration plate of the car in front of you whilst driving (but don't worry about recording the answer anywhere I don't want you 'rear ending' anybody). It won't take long before you are a mental arithmetic 'wiz'.

Annex A. Mental Checklist

Annex A

Mental Checklist

In order to ensure that everything we need to do is done in the correct order of priority, and nothing is omitted each time we correct track and ETA, or turn onto a new leg of our flight (including our initial departure), I recommend using a mental checklist based upon a suitable mnemonic. The following is the one that I used to teach.

The mnemonic is: **CLEAROFF**

Each letter in this mnemonic represents an action to be taken immediately after departing the start point and each waypoint, and at each checkpoint (even if no heading alteration is required). Each letter is amplified as follows.

- C. Compass.** Turn onto the new heading and re-synchronize the directional gyro (DI) with the magnetic compass. (Caution; only do this wings level so that magnetic ‘dip’ does not distort the reading. Also read the actual heading on the compass, do not just say “oh it’s 10° left of 030° (say)”, and set the DI 10° left of 030°, because the DI display is the ‘mirror’ reverse of the compass and this will instantly introduce a 20° error.)
- L. Log.** Record the new heading in the HDG2 or HDG3 boxes (if applicable), the departure ATD (if applicable) and the ETA for the next waypoint in the appropriate boxes.
- E. Engine.** Check all engine power and mixture settings, and all temperatures and pressures to ensure the engine is functioning correctly.
- A. Altitude.** Check that you are flying at the planned altitude for this leg of the flight and, if not, go to this altitude. (Don’t forget to allow a ‘one off’ time correction for a climb at 30 seconds per one thousand feet.)
- R. Radio.** Make a position/departure report on the appropriate frequency using the data recorded in your Navigation Log. If not on full reporting procedures, make sure you are on the correct area frequency.

- O. Orientation.** You have now traveled a few miles along your planned track. Pick up the map, align the track marked on it with the fore and aft axis of the aeroplane, sit back and look out the window. See if the ‘big picture’ you see corresponds with the main features of the map. This ensures you have not made a ‘goof’ by steering the wrong heading. (This step is not so important at checkpoints where the established heading is being ‘fine tuned’.)

- F. Future Times.** Record on the map, the times you expect to be at each of the future checkpoints on this leg.

- F. Fuel.** Check and record the fuel state on the fuel graph, and ensure the fuel flow is as planned. (See Lesson Eight for details on creating a fuel graph.)

Quite often, when everything is going very well, you will get this nagging feeling that you have forgotten something. When this happens, simply scroll through this mnemonic/checklist in your mind to assure yourself that ‘all bases’ have been covered. Then relax and enjoy the flight.

LESSON FIVE

TRACK CRAWLING

What if we are in a situation where the terrain over which we are navigating is fairly sparse and the track we have planned takes advantage of the only decent pinpointing features around? Obviously we would prefer to remain on the pre-planned track rather than adopt a new track from our point B pinpoint (assuming it is off track). In these circumstances we can introduce a variation to the procedure.

Let us assume that the feature at checkpoint B is the only one around, and is visible from a few miles away, or at least a line feature leading to it is. Let us also assume that our tracking errors have caused us to be 'X' miles off track abeam B. Then as we pass abeam B we turn and head toward it noting the time at which we turn. When we reach B we pinpoint it on the map in the normal way and turn onto our original heading. Then quickly, before the errors cause us to depart track again, we calculate the time from the turn to arrival at B, let's say it took 1 minute, then our turn was made at a point 2 miles abeam B, that is we were 2 miles off track. (Refer Figure One)

Using the 1:60 rule we calculate the track opening angle and alter heading by that amount. Note that we don't worry about the closing angle because we have put ourselves back on our original track by flying to B, and the new heading should keep us on track. We can update our ETA's in the normal way using the time at the turn point as if it were a pinpoint, but we must add on the 1 minute we spent flying to B when revising our ETA's for C & D (as a 'one off' timing correction). This can be repeated again at C if necessary. This technique is often called "TRACK CRAWLING" and is the basis of the technique used in low level navigation.

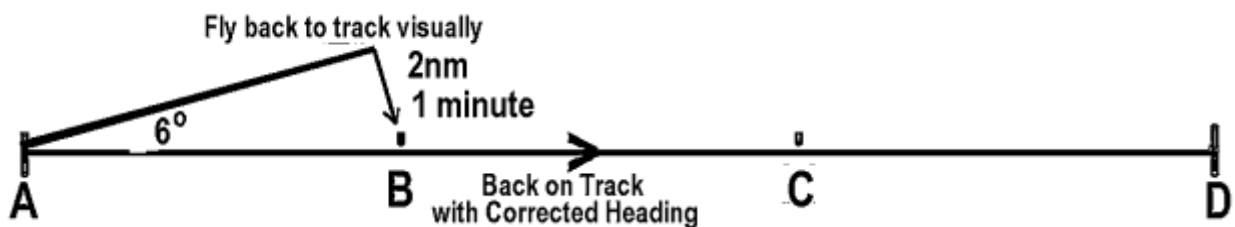

Figure One

LESSON SIX

LOW LEVEL NAVIGATION

Wherever possible fly your route at least 1500ft. above ground level. Two major problems arise when forced to fly lower:

- A You cannot see as far to pick up navigation features.
- B Wind errors can vary due to the proximity of terrain causing local wind changes.

On the plus side, minor hills which would not be obvious at higher altitude, can become the principle navigation feature when at low level. So practice reading the contour lines or layer 'tinting' on the map during your practical navigation training too, because the hills they define are more obvious at low level.

Occasionally due to weather or airspace restrictions we are forced to fly lower. The airspace requirements are usually associated with light aircraft lanes through Controlled Airspace and usually follow clearly defined features such as rivers or railway lines. This style of navigation presents little problem because you simply follow the feature. Weather related low flying is another problem.

Weather related low flying is not normally pre-planned so in-flight planning errors are likely to be present. Our pilot navigation principles still apply but we use the track crawling technique and reduce our fixing cycle to 5 minute intervals (approximately) to avoid ever being too far from track.

To prepare the map, divide the track into thirds then put marks half way between those marks (1/6). We use our 1/3 and 2/3 points for ETA updating as usual, but we should pinpoint our position and correct our tracking every 1/6 (5 min. approximately). Attempt to stay within half mile of track at all times (1/2 mile in 10 = 3°), and track crawl to destination.

In areas of rugged terrain we often have to adopt a combination of low level track crawling and feature following techniques (like flying through valleys etc). I have spent a lot of time flying in such terrain in Papua New Guinea and Irian Jaya. It was spectacular, challenging flying, often in treacherous weather conditions. Being able to quickly change plan and take alternate routes was a regular necessity. Good maps, good map reading and good time keeping is essential in these circumstances.

LESSON SEVEN

GETTING LOST/GETTING UNLOST

If, due to poor preflight planning or inattention to the principles expounded in this book, navigational errors are made and allowed to increase uncorrected, it is possible to become **'LOST'**!

There are varying degrees of being lost, ranging from temporary uncertainty of one's exact location, through uncertainty of one's position within a certain area to hopelessly and totally unaware of where the hell you are!

Properly trained pilots should never fall into the last category unless they fall asleep for several hours enroute. The middle category is possible if some gross error is allowed to persist for a while; however, by adopting procedures contained herein the problem can be rectified. The first category is merely your own displeasure at your sloppy flying and, as long as the big picture is still okay, you are not really lost.

It is the middle category of **'LOST'** which will be dealt with here. I will say it again, it is: "uncertainty of one's position within a certain area". It is the second part of that statement that gives us a clue to the solution – "within a certain area". If you had a positive pinpoint only 15 minutes ago and you are doing 120kts then you must be within an area bounded by a circle 30 miles radius centered on your last pinpoint and probably somewhere near the rim of this area. So straight away we can see there is no cause for panic. Embarrassment and frustration at being so stupid as to allow this situation to develop, yes; but panic, no.

Indeed, we can probably narrow our most probable position down to only a segment of the total area with a little clear thinking - if a large city is in one quadrant and it can't be seen, you are not in that part of the area. If it is afternoon and the sun has been in your eyes for a while, you are probably in the western part of the area. These are just two general ideas to help eliminate the greatest thought stopper known - panic. Let's now look at a detailed plan of action to 'un-lose' ourselves.

First, what sort of errors, if uncorrected, can cause us to be lost? Referring back to earlier in this book - type A errors are the most likely cause. As for type B errors, winds are rarely so strong as to cause massive track errors in 10 - 15 minutes, inaccurate maps are never that inaccurate (at least in countries where private flying is common) and instrument malfunction is rare and can be detected with proper crosschecking.

Let's have a look at some of the type A errors which commonly cause navigators to become lost.

1. Inaccurate preflight planning: Miscalculating or mis-recording a track direction is the most obvious, followed by incorrect distance measurement, followed by incorrect application of wind velocity to tracks and speeds.
2. Inaccurate flying: Misreading the compass when synchronizing directional gyro's is the most common, closely followed by attempting to read the compass when in other than straight and level flight. Plus just plain old sloppy flying - not holding a heading reasonably accurately.
3. Slips or Goofs: Reading the wrong line of the flight plan and steering the next leg's heading instead of this one, or reading the wrong column and steering altitude as heading (!), or transposing numbers like steering 050° instead of 005°. Also misreading your clock and/or looking at the wrong leg on the map are also common mistakes.

Knowing the sorts of errors we can make can assist us in finding ourselves once we accept that we are lost. This is an important point: we must first accept the fact that we are lost and often this can be a difficult decision. The pilot mentioned in the introduction obviously did not accept that he was lost until much too late. (See Annex A for a couple more examples.)

If, when you get to your next check point, the features are not there, and the big picture does not confirm your general location, don't press on, do something. Accept the hypothesis that you could have made an error causing you to be lost.

Having accepted the fact that you are lost, what is the next step? The next step is simple: note the time - write it down; it will be useful shortly. Next, look outside and locate some feature, any feature which is obvious enough to be on a map somewhere and go to it. It may be a town, or a prominent river or a road (preferably sealed if it is going to be on a map) or even just the highest hill around. When you get to the feature note the time you took to get there and the general direction you went to get there. (If it was nearby this is not necessary.) When you get to the feature stay near it, it is your 'anchor point' whilst you sort out the rest of the problem.

Since we are now circling a point which is prominent enough to be marked on a map somewhere, we have to determine which part of the map to examine to find it. We now need to estimate our most probable position (MPP), otherwise we could spend forever hunting all over our map and not achieving very much.

To estimate a MPP we need to discover the error we have made to get us into this mess in the first place, so we check.

- a. Heading from last pinpoint - was it correct?

Was it -

- i. correctly planned?
- ii. correctly set on DI?
- iii. correctly synchronized with compass?
- iv. correctly flown?

- b. Time from last pinpoint - was it correct?

Was it -

- i. correctly planned?
- ii. correctly used to calculate next ETA?
- iii. did you misread your clock?
- iv. were you flying at the planned speed?

- c. What about silly mistakes?

- i. is the map orientated correctly?
- ii. does the heading we flew agree with the general orientation of the track on the map?
- iii. did we use information from the correct line/column of the navigation log?

- d. Is the DI serviceable?

Using this process of elimination you will find the cause of the problem.

Once the problem is identified the error is noted, i.e. DI 90 degrees out of sync with compass or steering heading from wrong line of the 'Nav Log' etc. Write it down also, because now we have the data to estimate our MPP.

Whilst continuing to circle our anchor point, draw on the map the real track from your last pinpoint based upon the error you have identified and mark on this track a point corresponding to the distance traveled to the time you first noted. This is our MPP. Centered on this point sketch a circle of radius equal to about 20% of the distance flown; this is the area of the map we are most likely to be in. If you traveled any significant distance to your anchor point from when you first accepted you were lost your MPP should be adjusted accordingly.

We now reverse our normal map reading procedure and work from the ground to the map. Study the features of your anchor point and locate anything within the MPP circle which corresponds with it. (You may find more than one.) Now you now have a possible fix (or a hypothesis of where you are), you can confirm or deny this possibility by working map to ground in the normal manner to find confirmatory features. During this process ensure you remain directionally orientated as it is easy to make features fit the map when you are getting desperate. Don't despair, you are not far from your MPP - you will locate your anchor point on the map in this region. If the feature is not readily apparent on the map expand the size of the circle you are searching in - it is there.

Presto! You find it - you are no longer lost. Whilst continuing to circle your anchor point, re-plan heading and time intervals back to where you want to be. Don't rush, double check everything - you are in a state of mind which is prone to error and we don't want to get lost again, do we? Depart the anchor point and adopt normal navigation procedures, out of there and home.

At the conclusion of the Lesson on Radio Navigation Aids (Lesson Nine) you will find more information on how to use these devices to help you get un-lost, even when you are hopelessly and totally unaware of where the hell you are.

In addition to all of the foregoing procedures you can still request assistance from the FSU you are currently communicating with. The Flight Service Officer can assist you to ascertain your MPP as he has been in receipt of your position reports and knows where you were a while ago. He is also familiar with the features in your area as he spends his working life communicating with aircraft in the area and looking at maps of the area. Since you help pay his salary, don't hesitate to use his services.

Finally there is radar. If you are within the coverage of a civilian or military radar station, even if your aircraft is not transponder equipped, the Flight Service Officer can liaise with them or direct you to one of their frequencies in order that they can locate your position and assist you to get to where you should be.

One further note to illustrate the sort of assistance that can be rendered by FSU's - a few years ago a private pilot became lost in Victoria. He found a town and circled it (anchor point) but could not figure out his *MPP*. He called the FSU and advised them of his situation. The Flight Service officer could not help with the *MPP* as the aircraft had not been reporting his position (normal?). So the Flight Service Officer telephoned prominent people (Police, Fire Brigades, etc.) in every town in the region to see if an aircraft fitting the description was circling overhead - eventually after nearly 30 minutes and 12 towns contacted, the aircraft was located. The irony was that it was only about 30 miles from where the pilot wanted to be!!

Annex A

Lost!?! Nah, it can't happen to me.

A very long time ago two young fighter pilots were given the job of ferrying a piston engine trainer 600 miles to their home base so that it could be reconfigured as a 'Forward Air Control' aircraft. One pilot was named Pete, and the other was me. I volunteered to be the navigator as I figured flying this 'toy' for that distance would get very boring. Just to make it interesting we decided to do the whole trip not above 200 feet.

A refueling, coffee and potty stop was planned about half way along our route. By the time we got there Pete was pretty stiff but the navigator was 'on fire', track +/- 50 yards ETA's +/- 10 seconds....all the way. Man was I good!

About two thirds of the way along the second leg we had to cross a mountain range and then find a large valley which would lead us home. Unfortunately there were a number of thunder storms along the mountain range which necessitated Pete taking avoiding action. This was no problem for a master navigator like me. I simply followed his track deviations and weaving with my thumb on the map for the next half hour until we had cleared the storms and the mountains. I then quickly guesstimated the new track to our destination, added on the 10°E variation and gave Pete a new heading to steer. I estimated the valley would arrive on the nose in about 15 minutes, so I relaxed and put the map aside for a while.

After 20 minutes, no valley! Nothing but trees as far as the eye could see. Pete was becoming a little agitated so I reassured him of my navigational prowess by redoing my calculations out loud. Upon hearing what I had done with the variation, he punched me in the head and altered heading 40° left! The valley appeared 10 minutes later and I meekly gave him a new heading for home base.....which he triple checked.

I bought the drinks in the bar that night! How could such a hot shot jet fighter pilot and low level strike navigator screw up navigating this toy aeroplane so easily? See if you can figure out the two errors I made.

Many years later I was given the job of 'umpire' for a low level tactical air delivery exercise named 'Bullseye'. The exercise was an annual competition between the best crews of the best tactical C-130 squadrons of three different air forces. This year's competition was to be conducted over routes around the middle of Quebec Province, Canada. Now the dominant feature(s) around the middle of Quebec is lakes, thousands of lakes, of all shapes and sizes, and not much else. My job was to fly with the crews of the other two air forces and adjudicate on the accuracy of their low level visual navigation (no radio,

Doppler or inertial navigation aids allowed), and the accuracy of their final time on target. They lost points for every 50 yards they missed a turn point (and there were over a dozen of them) and every second they were off their time on target, and every meter their load missed the 'Bullseye'. All of this was to be done not above 200 feet above ground level at 240kts. These guys were very good at their job.

I first flew with the Canadian crew who 'aced' in the whole task, which was good because I was suffering severe jet lag and was aghast at the number of beaver dam and log cabin turn points these crews had to find enroute. I was glad I could see the route first with guys who were used to this 'alien' landscape.

The next day came my flight with the New Zealand crew who flew well, right up until the time they miss identified one of the beaver dams. From that point on their track slowly diverged from the plan because each successive turn point was 'made to fit' their wishes. Ultimately, when they couldn't make things fit any more, the realization dawned on them that they were lost. But without any anchor points other than more lakes and beaver dams they all looked at me!

Fortunately because of my prior flight with the Canadian crew I still had a rough idea where we were, but we were rapidly heading off the edge of my map! Now the rules of the contest were quite specific about the Judge not assisting the competitors, but since it was now obvious that I was the only one in the cockpit who knew where we were I first had to disqualify them, and then I put my finger on the navigators map to indicate our position. His reaction was one of disbelief as he was sure that he had only missed one or two turn points, but when I told him it was six he went into a state of complete denial and steadfastly refused to believe me. He refused to believe me because, as I said in the main text of this lesson, it is hard to come to terms with that fact that you are lost when everything seemed to be going so well. His disbelief lasted all of 30 seconds because with some 'not so gentle' urging from the aircraft captain he quickly recalculated a heading to get us to the target so that they could at least drop their load. The target was found only 5 minutes late. Now 5 minutes late doesn't sound like much, but to these guys it might as well have been 5 weeks! So no trophy for the New Zealand crew that year and a salutary lesson for all.

For the record, the Australian crew won the contest by 2 points.

LESSON EIGHT

KEEPING TRACK OF FUEL CONSUMPTION

One significant aspect of navigating from A to D is having enough fuel to get to D! Now this might seem like an obvious statement, and whilst most pilots will ensure there is adequate fuel at the beginning of the flight, they will then take it on blind faith that the fuel consumption of the aeroplane will be what they have planned for, because most of them have no system of checking the rate of fuel consumption enroute.

History has proved that fuel gauges can be notoriously unreliable. Either the little plastic float in the tank ‘springs’ a leak and sinks or the electrical system passing the floats information to the gauge develops a bad earth or the gauge itself just sticks.

I once did a commercial licence test on a pilot with more confidence in the fuel gauge than ability to think. The aeroplane only had 2½ hours safe endurance and we embarked upon a 2½ hour flight. After about one hour of flight I noticed that the fuel gauge had not moved for a while, which meant the engine was either running on air, or the gauge had stuck. I casually asked her how we were going for fuel and she shot a quick glance at the gauge and said “okay”. A half hour later I asked again and got the same response. She had not noticed that the gauge was indicating the same level that it had a half hour before! I then asked if she thought that the gauge reading was what she should expect at this stage of the flight. Her response stunned me. She said “what, you want me to work it out in flight?” “Yes” was my reply, so she got out her navigation computer with a ‘huff’ and started ‘twizzeling’ the dial for about five minutes and then declared “yep, it’s okay”.

Due to significantly different winds than those forecast (she said) we had lost a lot of time on this navigation test (misidentifying one turn point didn’t help either) so I decided that continuance of the flight as planned was problematical. Using the ‘test’ as an excuse I asked her to divert to an airfield only 20 minutes away which I knew had fuel. This she did grudgingly and upon landing I asked her to once again calculate how much fuel should be in the tank. “40 liters” was her conclusion after 5 minutes of ‘calculation’. I then asked her to ‘dip’ the tank. Her hostility toward me was growing by the minute throughout this period until she read the dip stick.....10 liters!!! Her face fell off!

For the record, she was not one of my students and she didn’t pass the test. I met her again about six months later at another fuel bowser. She was there with a young pilot who I assumed was her instructor. I casually asked how her commercial licence training was going with this guy. She replied in a not too friendly manner that she was *his* instructor.....my face fell off!

The technique I learned for keeping track of fuel consumption in the Sabre, and I taught to all of my navigation students involves the use of a simple graph. It is based upon the quite reasonable assumption that once the engine is set up for the cruise its fuel consumption rate will remain constant, so a graph of fuel remaining versus time can be created. The following is an example of what I mean.

If the aeroplane's fuel tank can hold 120 liters and the aircraft flight manual declares that, at recommended cruise power, the engine consumes fuel at a rate of 30 liters per hour (its fuel flow), it is a simple matter to create a graph which looks like this, (Fuel Graph One).

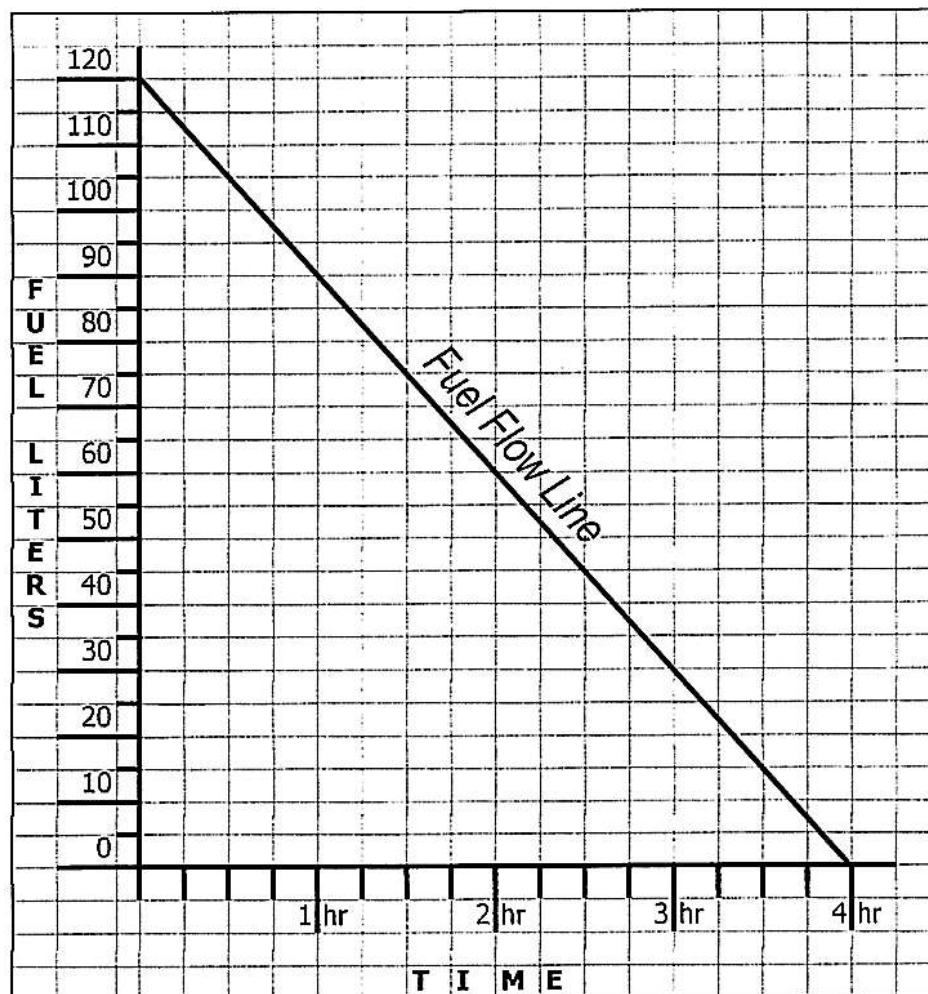

Fuel Graph One

The line created is the 'fuel flow line' and the slope of this line represents the expected fuel flow for this aeroplane. It is then an easy matter to enter the time axis of the graph at any particular time and determine how much fuel should be remaining. In the following example (Fuel Graph Two), you can see that after 90 minutes of flight there should be 75 liters remaining. This 'reading' can then be compared with the fuel gauge reading to determine the gauges 'veracity'.

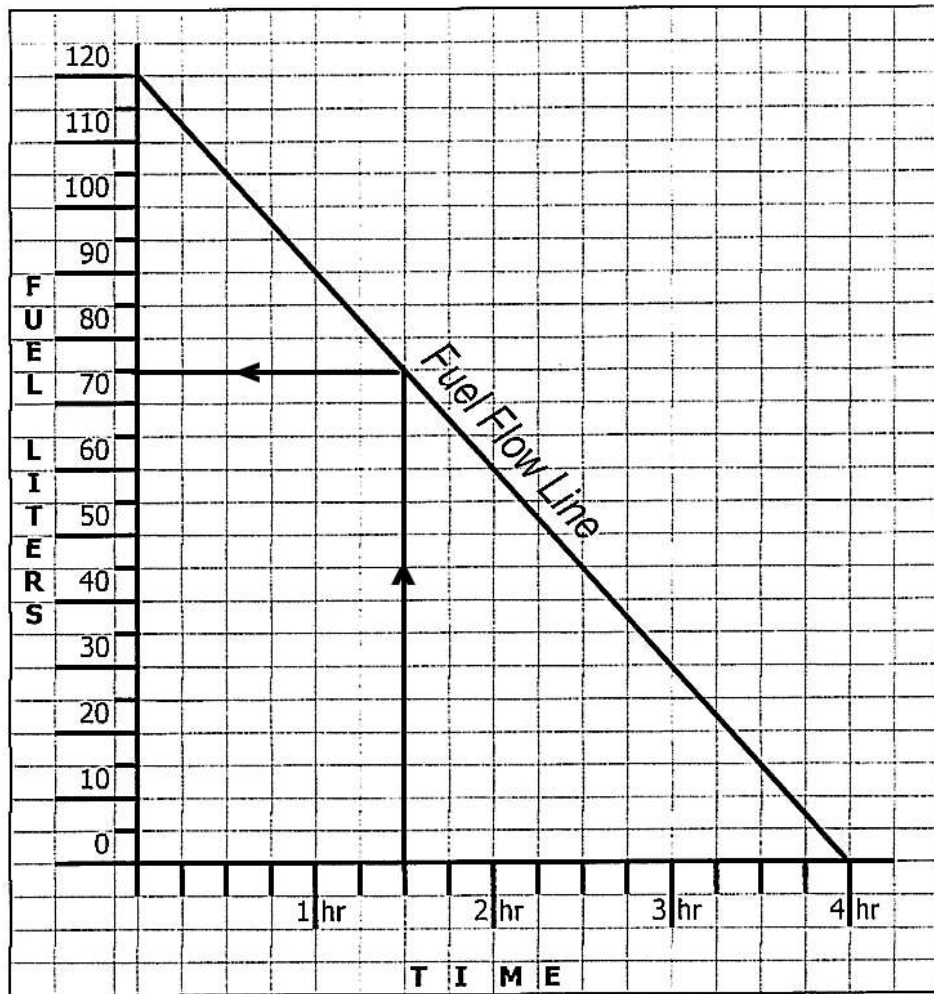

Fuel Graph Two

Also, along the time axis of the graph small boxes can be created where the actual time for each 30 minutes of elapsed time can be recorded. Real time entries can be made in these boxes once you have departed and your departure time is noted on your navigation log. The following is an example of these boxes, (Fuel Graph Three).

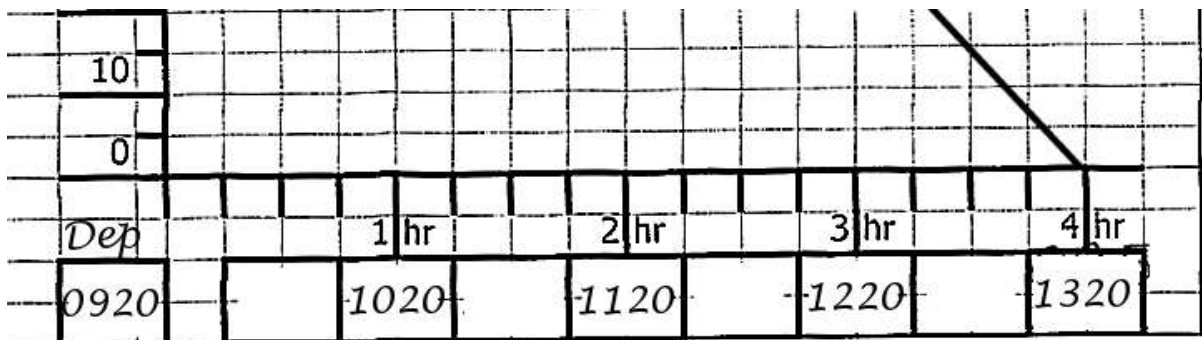

Fuel Graph Three

Now, so far, this graph has been over simplified. We obviously need to allow for those phases of flight where the fuel flow is greater than at cruise, such as during take off and climb to cruising altitude. So at the top of the graph we start the fuel flow line, not from the maximum tank capacity but from a level which allows for this extra fuel consumption, say 10 liters down. (Note this is just the extra fuel used during the climb not all of the fuel used, as the cruise fuel flow component is contained within the graph.) Also, depending upon the aeroplane, an allowance for start/taxi/warmup should be made, say 5 liters. So the fuel flow line now starts at 105 liters (120-15). Now we obviously don't run to 'tanks dry' either, so a 'bottom line' based upon the fixed fuel reserve we are using is also marked. The intersection of this line and the fuel flow line defines the aircraft's 'safe endurance'. (The very bottom line should also allow for any unusable fuel too.) The following example shows these modifications, (Fuel Graph Four).

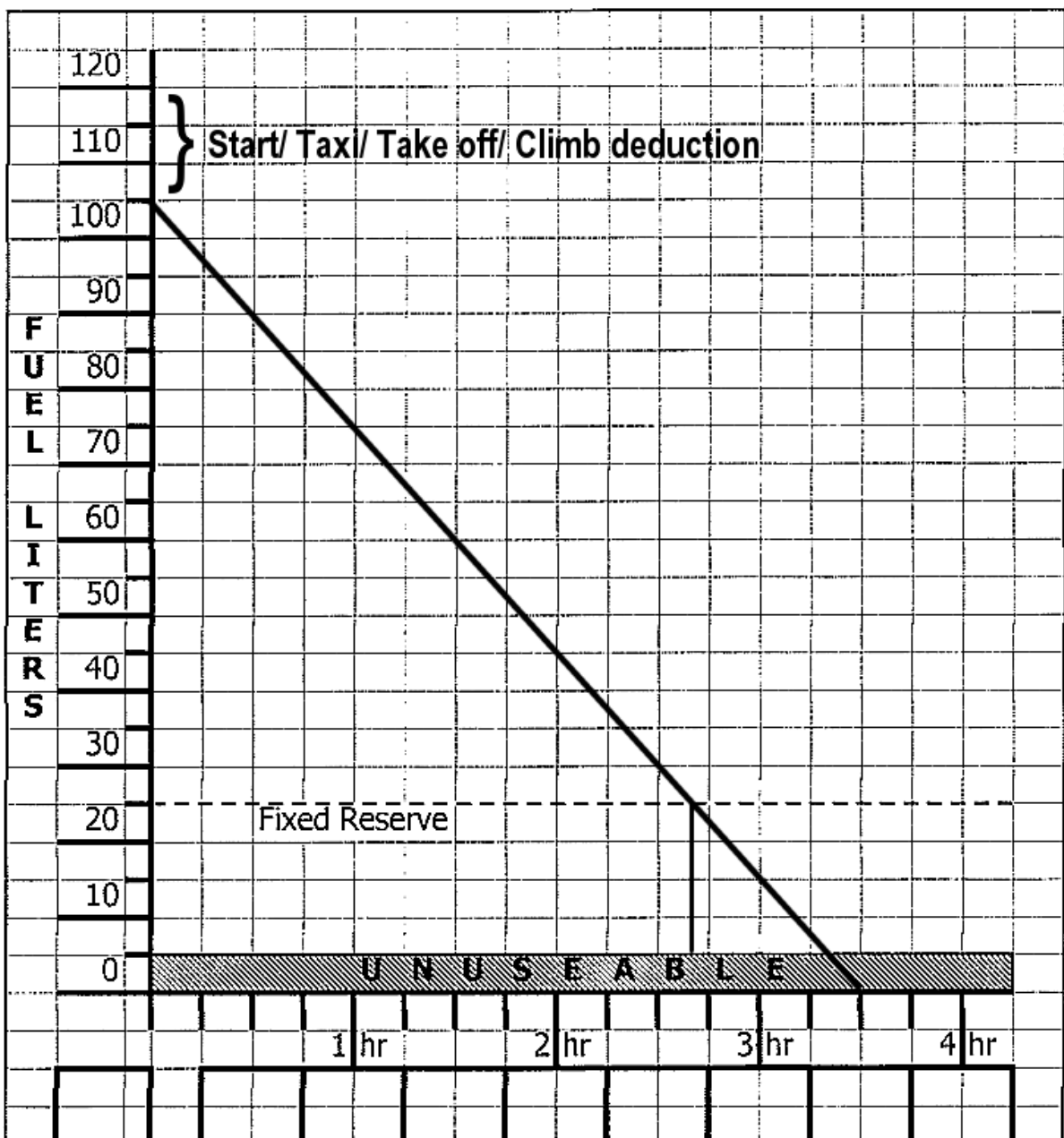

Fuel Graph Four

If you are confident in the reliability of your fuel gauges, the fuel gauge reading can be 'plotted' on the graph during flight, to confirm (or deny) that fuel consumption is what you expect. This is done by plotting two or three gauge readings and connecting the 'dots' to establish a new fuel flow line. The slope of this line is the actual fuel flow. Projecting this line to the very bottom of the graph will tell you when your fuel tank will run dry, or to the fuel reserve line to tell you when you should be landing. The following example illustrates, (Fuel Graph Five).

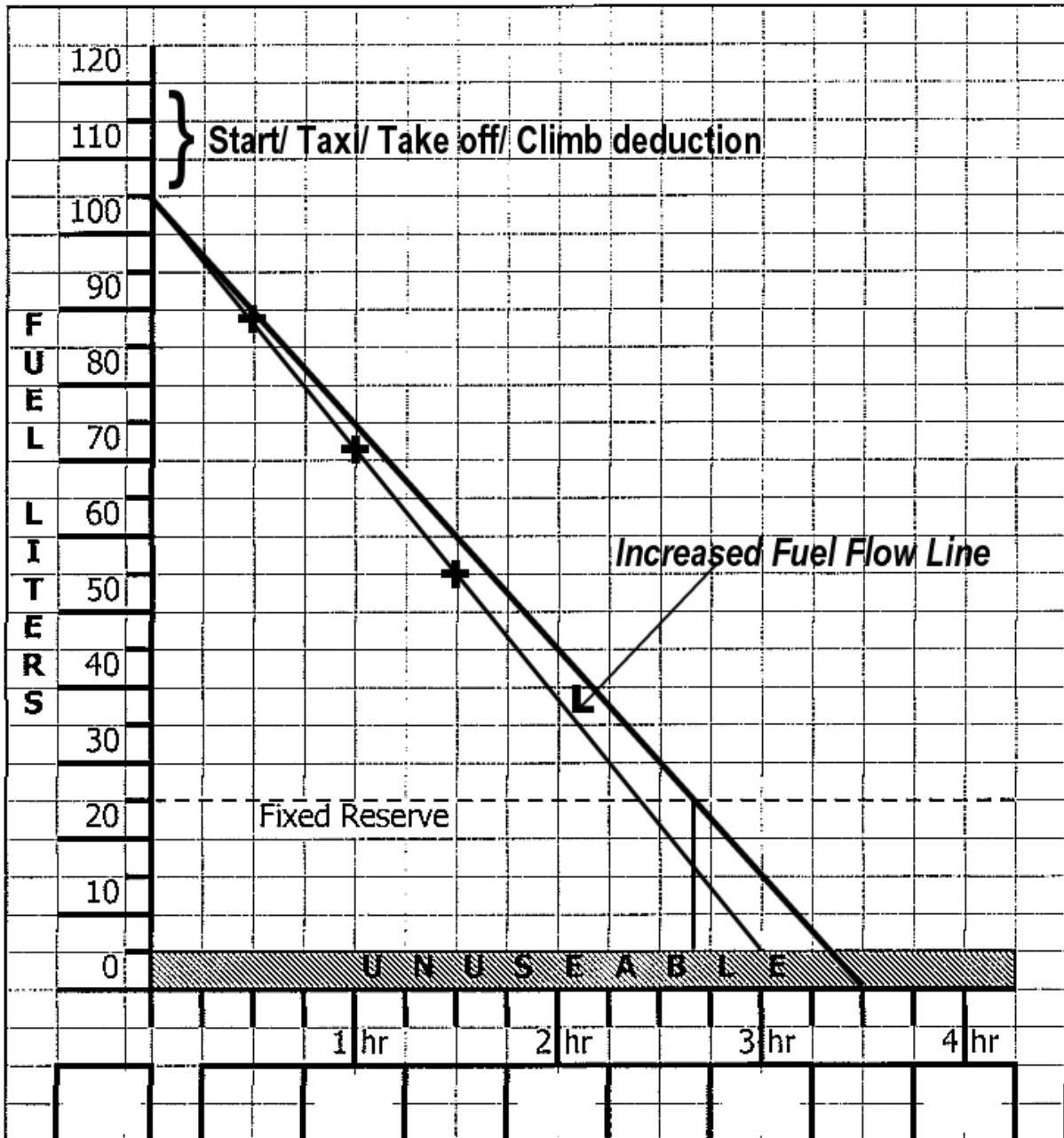

Fuel Graph Five

You can see from the forgoing that because of the increased fuel flow the remaining safe endurance (from the 90 minute check point) has been reduced from 70 minutes to 53 minutes. (Time enough to do something about it.)

I recommend that these fuel gauge readings be plotted about every half hour so that you can determine your fuel flow well in advance of the fuel consumption becoming critical.

Many years ago I was on a training navigation exercise in an aeroplane with four separate fuel tanks. We were running on one of the 'tip' tanks which should have given us about 1.3 hours flight time. The student pilot had noticed that the gauge reading for that tank, and the one we had been running on during the initial take off and departure, were reading lower than expected, and was discussing the possible cause of this anomaly with me when the tip tank ran dry and the engine failed! Changing tanks brought about a resumption of power but this occurrence suggested we had a more significant problem than an aberrant fuel gauge. Plotting the amount we had obviously consumed against the time of engine failure, created a fuel flow slope much steeper than expected, and projecting this slope to the bottom of the graph showed that we would have insufficient fuel to complete the task. It showed we had a 30% increase in fuel flow and that we had just enough fuel to get home if we diverted now, which of course we did. The fuel gauge reading/plotting cycle was increased to once every 15 minutes which confirmed our increased fuel flow had stabilized and confirmed we were going to make it home okay. Examination of the carburetor after landing revealed that the float inside had sprung a leak and sunk, causing the float bowl to flood and deliver an excessively rich mixture to the engine despite the lean mixture control setting. Our fuel graph had given us the ability to determine this increased fuel flow and decide on the appropriate course of action in a timely fashion, thus avoiding a critical fuel state situation.

I have also used this graphic technique to calibrate my fuel gauges as follows. Start a flight with a full tank of fuel then note the time that the 'key' gauge readings occur. For instance, your gauges may only be marked with "1/4, 1/2, 3/4 and Full" markings, so note the time that each occurs on the graph as short vertical lines and also note the time of engine shut down. Now refuel the aeroplane and note how much fuel it took. This will of course define how much fuel remained in the tank at shut down. Plot this remaining fuel figure on the graph at the time of shut down and draw a line back to the start fuel load (allowing for start/ taxi/ etc as previously discussed). This line will show you the actual fuel flow of your aeroplane at cruise; the points where this new fuel flow line crosses the short vertical lines define the actual fuel level at each time the gauge indicated one of those 'key' points, enabling you to make a calibration card to display next to the gauge for use on subsequent flights. The following is an example of a fuel graph used this way (Fuel Graph Six).

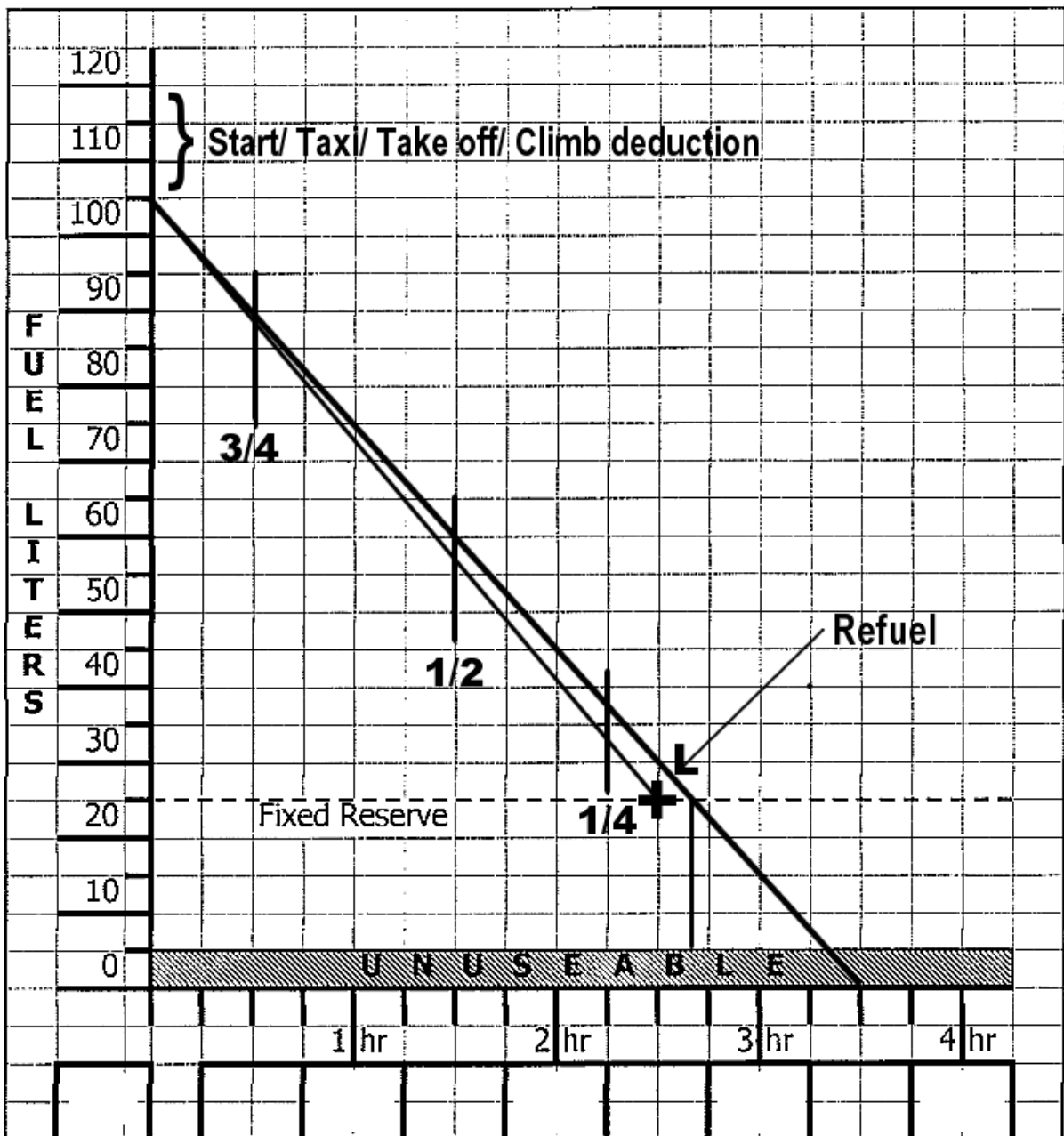

Fuel Graph Six

Now it is not necessary to create a graph from a blank piece of paper each time you go flying. Once the basic graph has been created for your aeroplane (on a computer or by hand), including an expected fuel flow guide line (the 'full tank' fuel flow line will do), as many copies as you wish can be made for that aeroplane. All you have to do prior to each flight is determine how much fuel you are actually starting with this time and draw a new fuel flow line from that starting point parallel to the guide line. You may even mark the names of way points and destinations at the time you expect to be there, thereby giving you an indication of the fuel you expect to have at those points. Fuel Graph Seven illustrates a fuel graph for the same aeroplane commencing a flight with 90 litres in its tank. Its safe endurance is now 100 minutes.

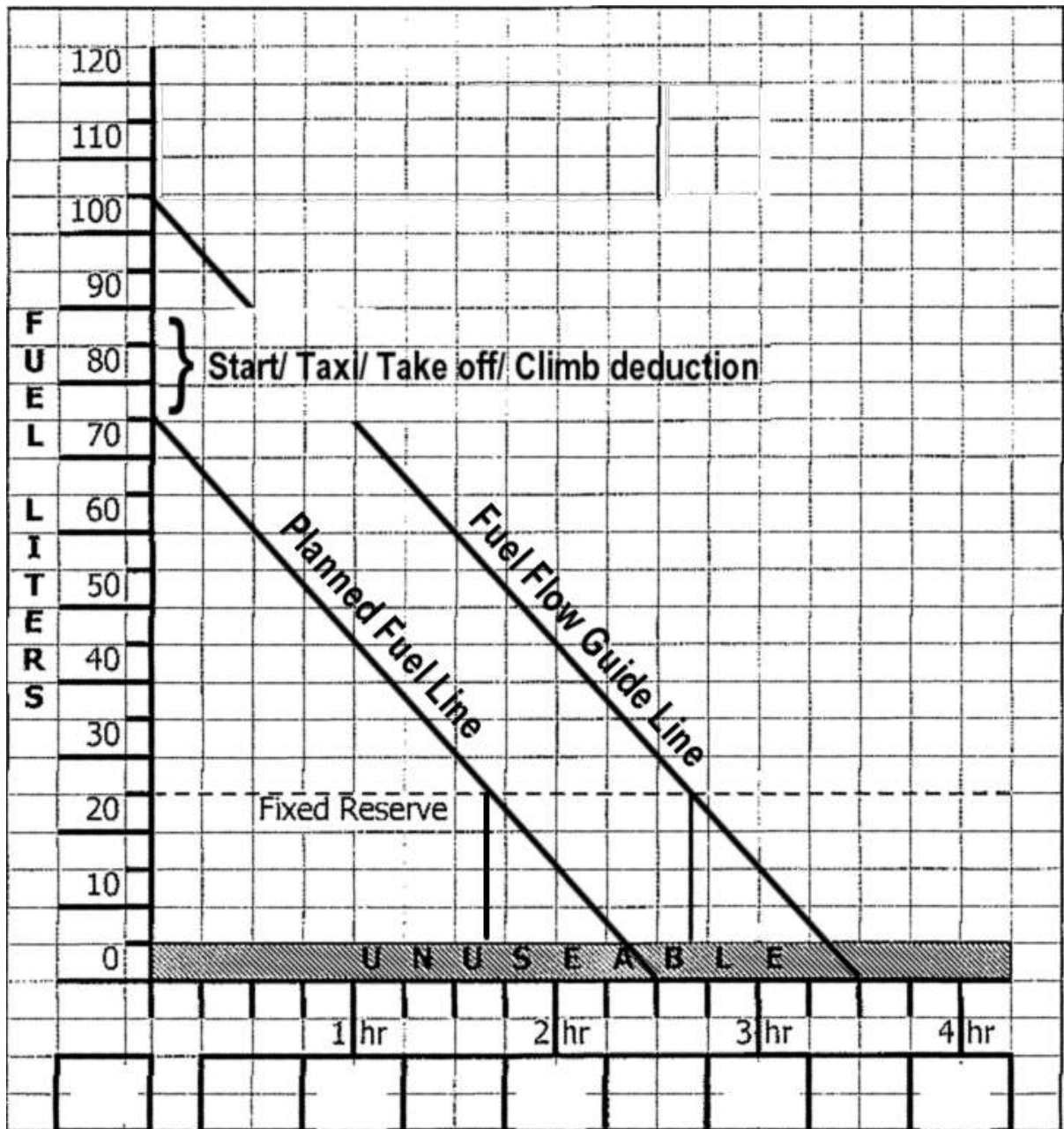

Fuel Graph Seven

If you land at an intermediate destination and do not refuel, dip your tank and use that level as the starting point of a new graph for the next leg of your journey, (allowing for start/ climb/ etc) as shown in Fuel Graph Seven. This is easier than trying to use the old graph again and after all, it is only a piece of paper.

The half hour fuel recording cycle runs independently of your navigation cycle as rarely do 'way points' occur every half hour, but this is a good thing as it spreads the workload through out the flight. If you miss an exact 30 minute fuel check there is no problem, simply interpolate the time along the time scale and plot the current fuel level above that.

I have attached, as annexes, examples of two fuel graphs I created for two of my aeroplanes (the second also shows the navigation log I use). You will note that there is an additional 'box' on each of them which enables the individual fuel gauge readings to be recorded beneath each 'key' time interval too. This is handy in multi tank aeroplanes and enables these individual readings to be totaled so the total can be plotted on the graph.

Remember, "The air in your tanks is as useless as the runway behind you and the altitude above you". Also, "the only time you can have too much fuel in your tanks is when you are on fire!" **There is no excuse for running out of fuel.**

Annex A. Fuel Graph for Pitts S2S

Annex B. Fuel Graph for Siai Marchetti SF260

LESSON NINE

RADIO NAVIGATION AIDS

The use of radio navigation aids can become a complex subject when their full application to instrument flight conditions has to be learned. For the VMC private pilot navigator the situation is not so complex. It should be emphasized at the outset that these electronic devices are AIDS to navigation only - they do not navigate for you, and if you can't navigate you are going to get just as lost with or without them.

The primary use of radio navigation aids in VMC navigation is to provide a confirmatory position line to increase the certainty of a pinpoint.

In Figure One an aircraft proceeding from A to D is expecting to cross a railway line near B, but when it does cross the railway line, the pilot cannot say "I am at B" because he could be anywhere along the railway line - a further feature is needed to pinpoint the aircraft position.

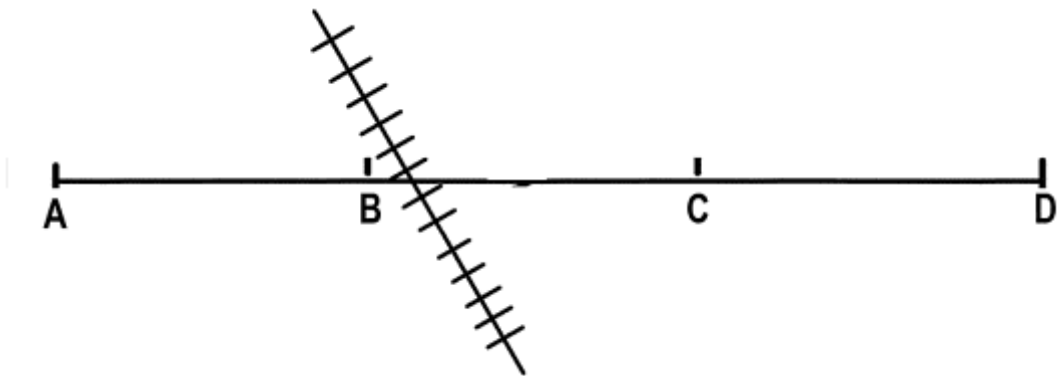

Figure One

If another line feature, such as a road or river, crosses the first (Figure Two), then this intersection defines an exact position which can be 'pinpointed'.

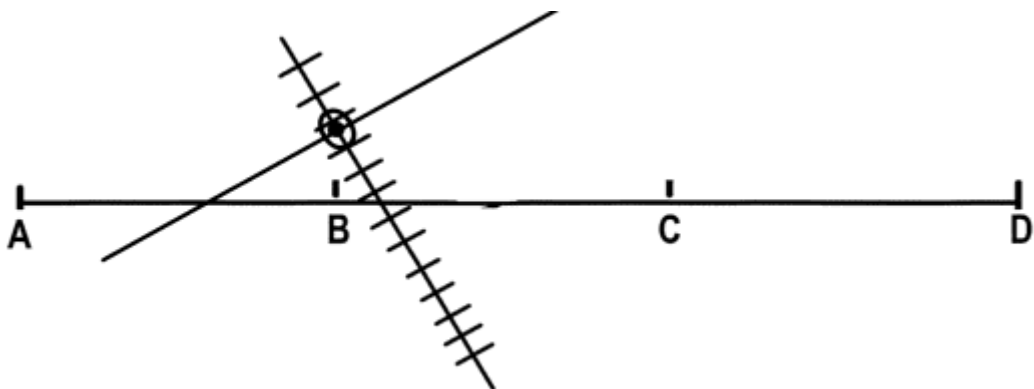

Figure Two

If there were no other features along the railway line, then a radio position line could be used to help pinpoint the aircraft.

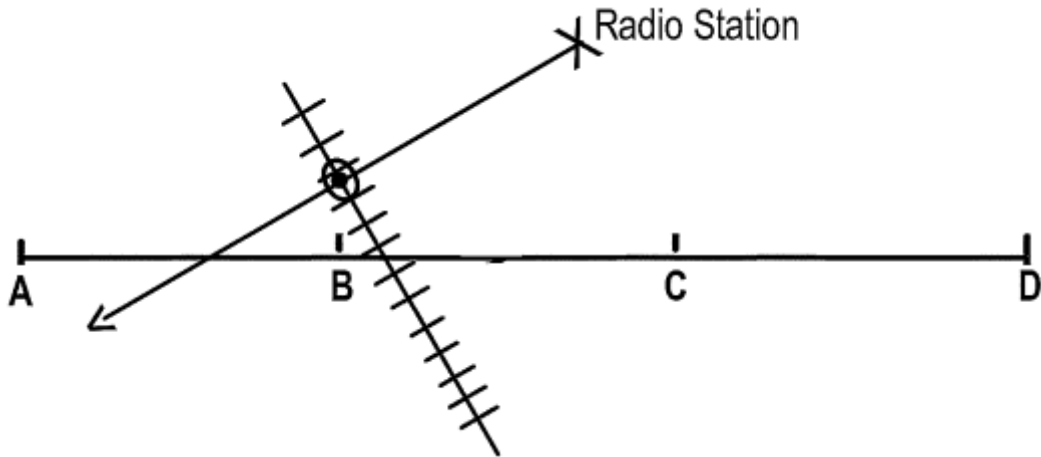

Figure Three

In Figure Three, if our aircraft is somewhere on the railway line and somewhere along the position line from the nearby radio station – then it must be at the intersection of these two position lines. Its position can therefore be pinpointed and all normal navigation procedures can be used to continue the flight. The question is, how do we determine the position line from a radio station?

TYPES OF RADIO AIDS

There are three common types of radio aids, they are:

- a. Distance Measuring Equipment (DME)
- b. VHF Omnidirectional Radio (VOR)
- c. Automatic Direction Finding (ADF)

each provide the pilot with position lines. However there are two different types of radio position lines, Radials and Arcs; DME provides Arcs, whilst VOR and ADF provide Radials.

ARCs

The DME indicates to a pilot his distance from the radio station, which means that without another position line all a pilot knows is that he is somewhere on the circumference of a circle that distance from the station (Figure Four).

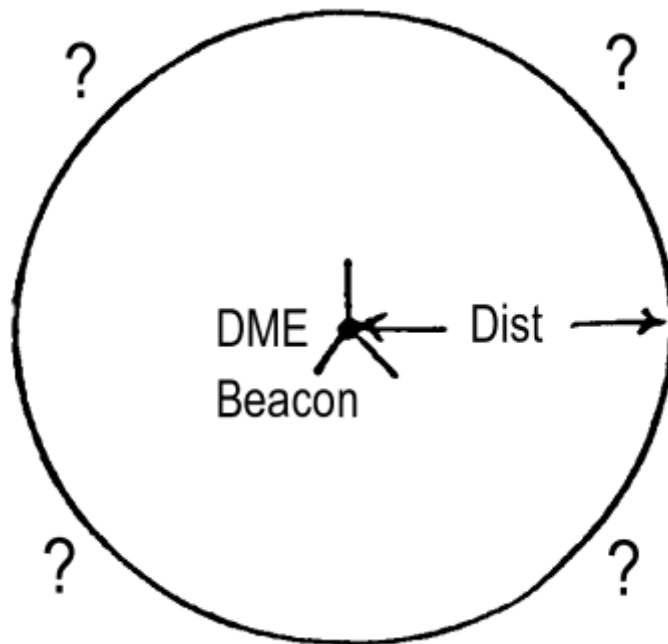

Figure Four

Using normal navigation techniques a pilot can refine that situation because he expects to be on that arc of the DME circle near B, so this arc can be used as a position line in conjunction with the other physical features on the ground. Figure Five shows this use of a DME arc as a position line crossing a railway line near B, and therefore pinpointing the aircraft's position.

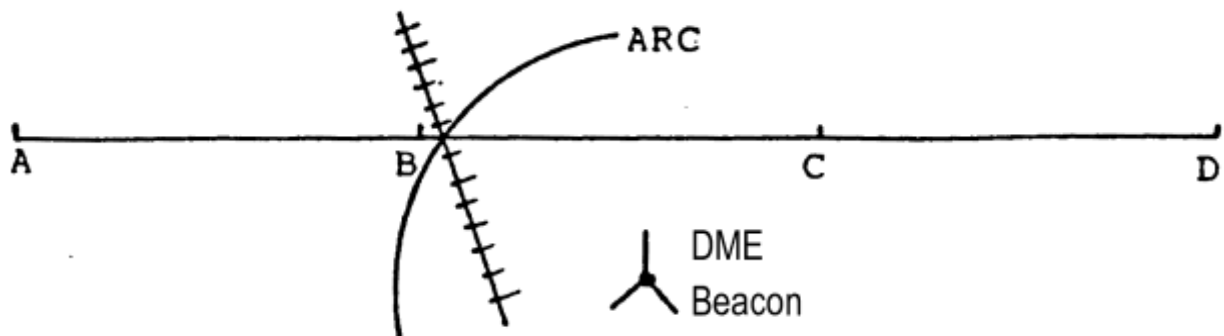

Figure Five

RADIALS

Radials are imaginary spokes emanating from a radio station like the spokes of a bicycle wheel - each, one degree apart; therefore there are 360 spokes or radials in the circle surrounding the radio aid. Refer to Figure Six. (Only radials every 30° are shown for clarity.)

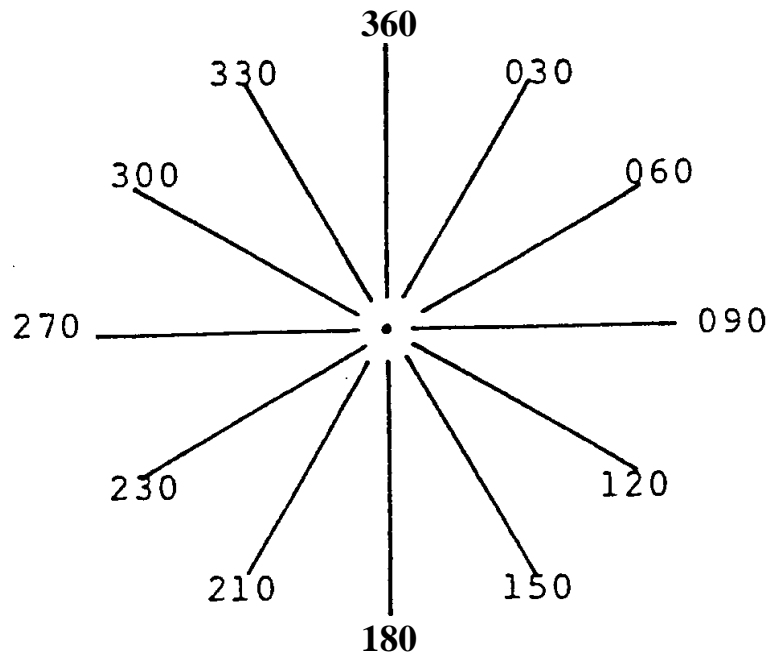

Figure Six

If we are due South of the radio station then we are somewhere on the 180° radial from it. If we are East of the station then we are on the 090° radial from it, etc. Referring back to Figure Three, the aircraft crossing the railway line is also on the 240° radial from the radio station. Note that the reciprocal of the Radial from the Station is the track to the Station.

HOW TO USE RADIO POSITION LINES

The easiest and most effective way to use radio position lines is to preplan them and mark them on the map. For example, a flight from A to D passes a VOR station enroute - the radials of Point B and C can be preplanned as shown in Figure Seven.

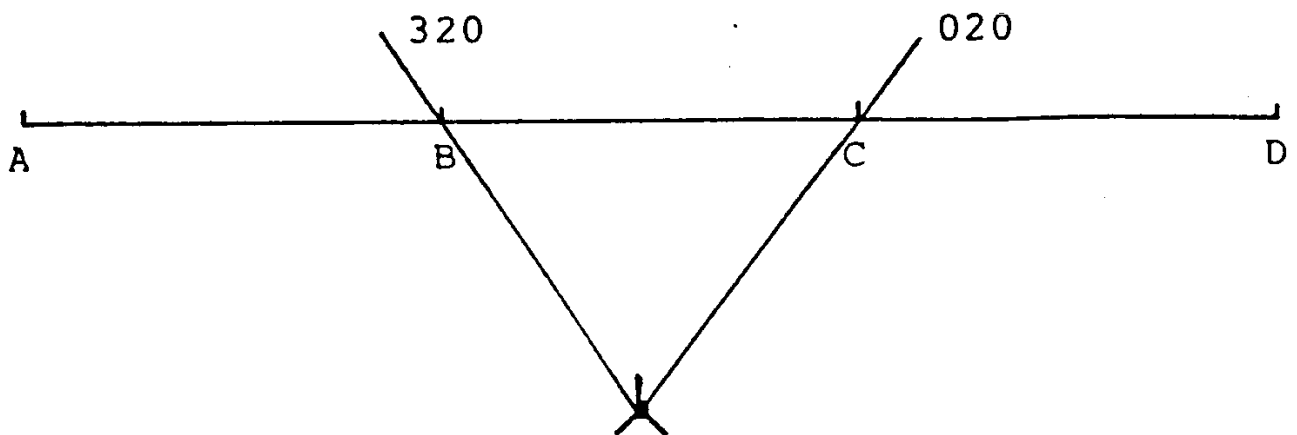

Figure Seven

It is important to note that the radials obtained from both VOR and ADF are MAGNETIC RADIALS, so you MUST ALLOW for VARIATION when recording the radial on the map. In Figure Seven the radial lines were drawn on the map from the radio station to points B and C, their direction was measured with a Douglas Protractor and the variation applied **before** writing the number on the map.

For this method to be accurate it is also important that the correct position of the radio station is plotted on the map. So when planning a flight, ascertain from the appropriate chart those stations which may be of use to you enroute and then determine their exact location in latitude and longitude, and plot this position on your map before drawing in the radials you wish to use.

Once this preflight planning has been done, the radio position lines you have drawn on the map can be treated in the same way as roads, railway lines etc, in determining your position. Obviously you will not see this line on the ground, but your cockpit instrument will tell you when you are on the radial and this can then be related to the other ground features.

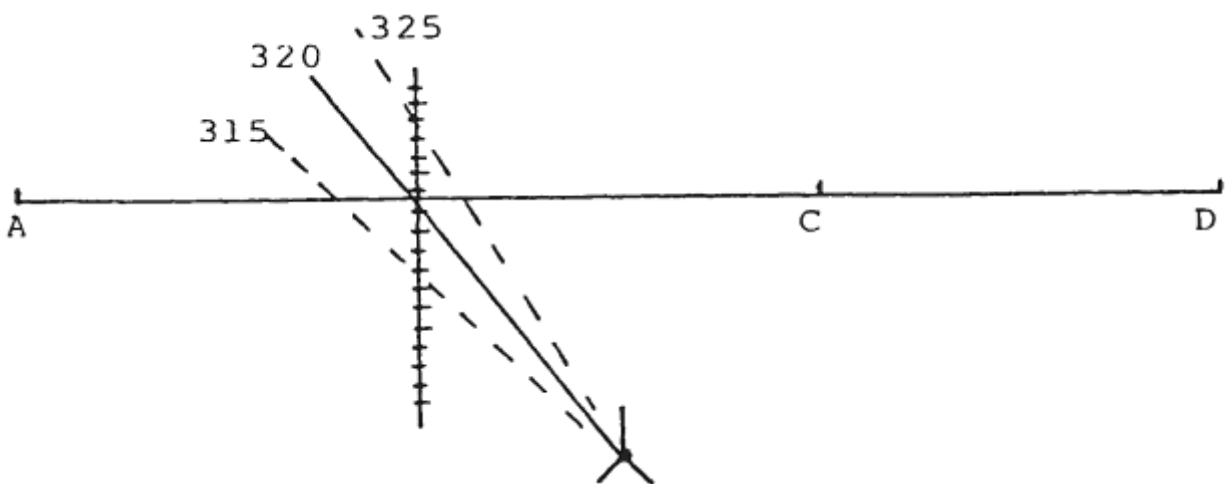

Figure Eight

In Figure Eight we have preplanned a radio position line (radial) to intersect a railway line at point B. If we are on track at point B we will cross the railway line as the cockpit instrument indicates '320°'. If we are off track then the instrument will indicate an angular difference from the preplanned radial as we cross the railway line. This angular difference will indicate the extent and direction of our track error. For instance, if in Figure Eight the cockpit instrument indicates '325°' as we cross the railway line, we are left of track, if it indicates '315°' we are right of track. The distance off track that this represents can be ascertained by 'eyeballing' a line 5° from the radio position line you have marked on the map and projecting it to where it crosses the railway line.

Another way of using a radio position line when off track, is to note the time the radio position line is crossed and the time the railway line is crossed. Using the aircraft's groundspeed of 2 nm/minute this time difference can be translated into a distance between the two position lines. (Ref Figure Nine.)

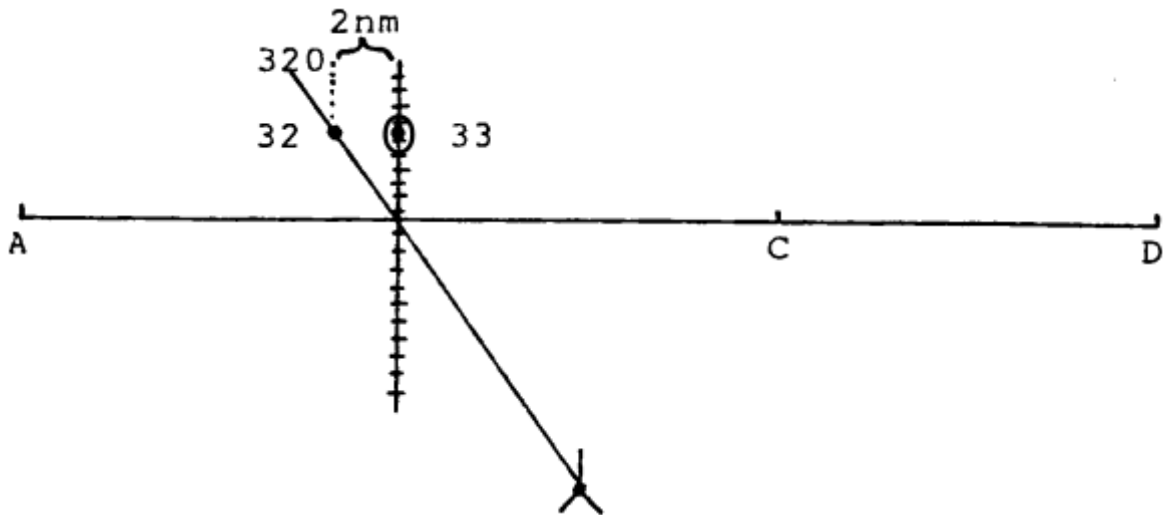

Figure Nine

If the radio position line was crossed at Time 32 and the railway line was crossed at Time 33 then there was 2nm between the two crossings. Inspection of the position lines on the map will reveal the distance off track required for this to happen. Obviously if the railway line was crossed before the radio line we would be on the other side of track. In Figure 9 we can mark the point on the railway line at Time 33 as our pinpoint and apply our normal navigation procedures from there.

Let's look at another example of how radio position lines can aid our visual navigation. Imagine that our track crosses a straight line feature with other obvious features along it. Figure Ten is a railway line with 4 evenly spaced wheat silos.

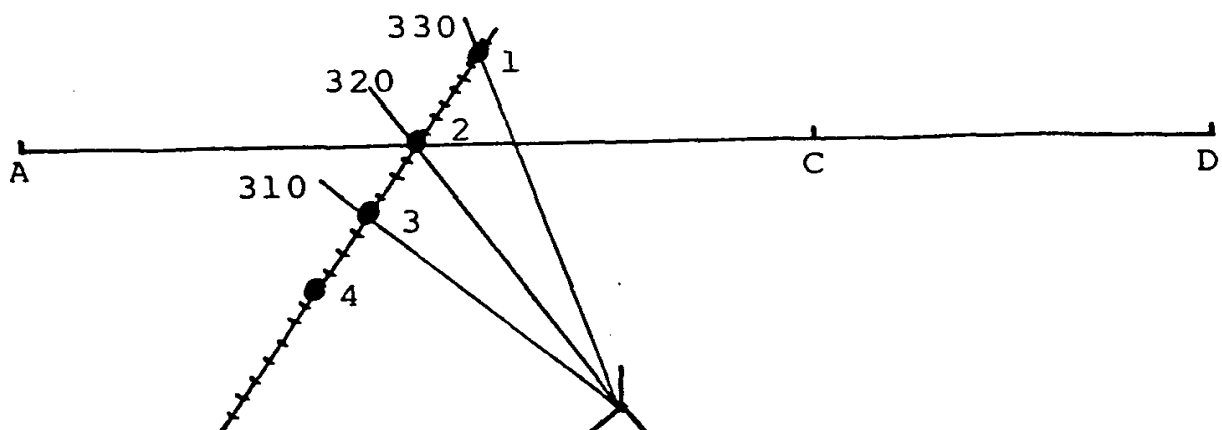

Figure Ten

We are supposed to pass over the second silo from the north, but it is a hazy day and visibility prevents us from seeing more than one other silo in either direction. We arrive over the railway line between two silos which we can see, and estimate we are two miles south of the one to our north - but which one is it? Radio position lines preplanned to the silos will resolve the ambiguity. If we are between the 330° and the 320° radials we must be south of silo number 1, if we are between the 320° and the 310° radials we are south of silo number 2.

So far we have only considered the use of radio position lines which are radials; however, the use of DME Arcs is very similar. Using the same scenario as Figure 8 but assuming the radio station is a DME beacon, the following results (Figure Eleven).

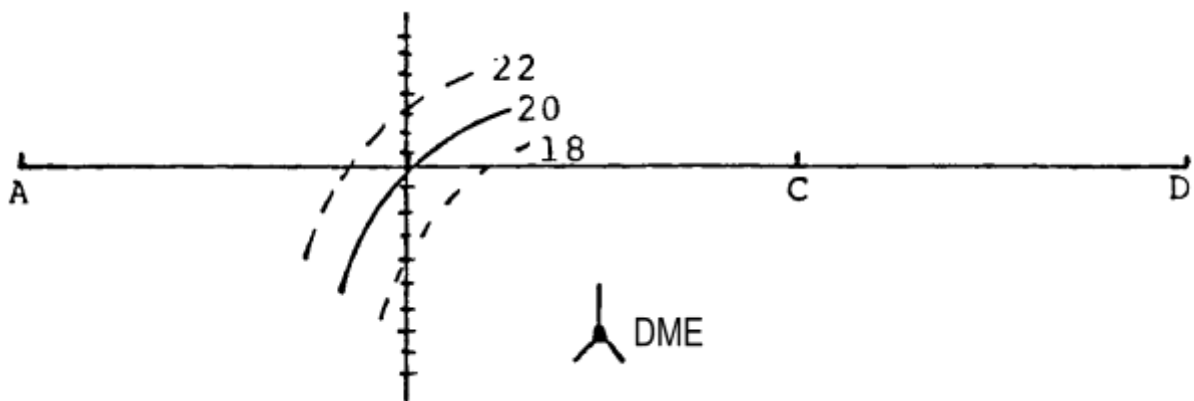

Figure Eleven

In Figure Eleven we should cross the railway line at 20 miles DME, if we cross it at 22 miles DME we are left of track, if we cross it at 18 miles DME we are right of track. The distance off track can be determined by 'eyeballing' a new ARC 2 miles from the one marked on the map. The 'two times' method detailed at Figure 9 can be used in a similar fashion.

Remember, these radials and arcs are position lines; the nature of the radio station which generated them is not too important. Once you have drawn the radio position lines on your map, you use them in the same way you would a road or power line, etc.

GOING TO OR FROM A RADIO AID

Frequently aircraft depart directly from or arrive at, points which are co-located with radio navigation aids. In these instances, in addition to using position lines from these aids solely in the manner so far discussed, they can also be used to simplify our track correcting technique.

Tracking FROM a Radio Aid

When tracking from a Radio Aid our track is the same as the Radial from the Aid.



Figure Twelve

In Figure Twelve an aircraft has departed from an airfield with a radio aid. The radial that it should be on at Point B is the aircraft track, but if it is not on track the cockpit instrument will indicate an angular difference. This angular difference is the opening angle, so we do not need to use the 1:60 rule to calculate the opening angle, it is provided. We can simply use this angle to calculate our heading correction in the normal way.

Tracking TO a Radio Aid

When tracking to a Radio Aid our track is the reciprocal of the Radial from the Aid. To avoid becoming disorientated it is best in this instance to set the cockpit equipment to indicate 'Track TO' and not 'Radial FROM'. (More on this in Annex B.)

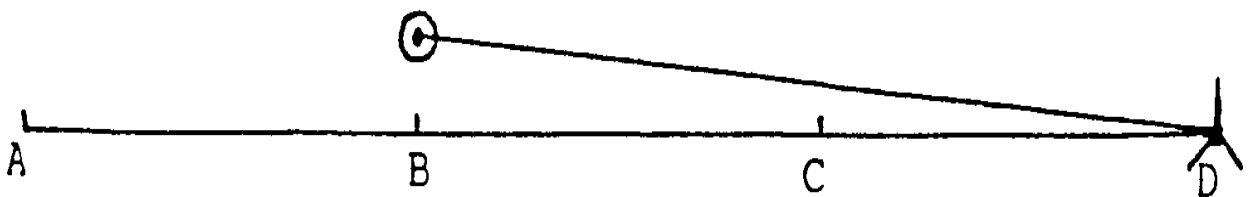

Figure Thirteen

In Figure Thirteen the aircraft has been pinpointed off track at Point B helped by a radio position line from D. The track to the destination is now different from that planned, and this angular difference is the closing angle. From that we can calculate the opening angle and total them to give the heading alteration.

How can we use a radio aid at destination to close with destination if we are already flying on a corrected track following an earlier heading correction at B? Check out Figure Fourteen.

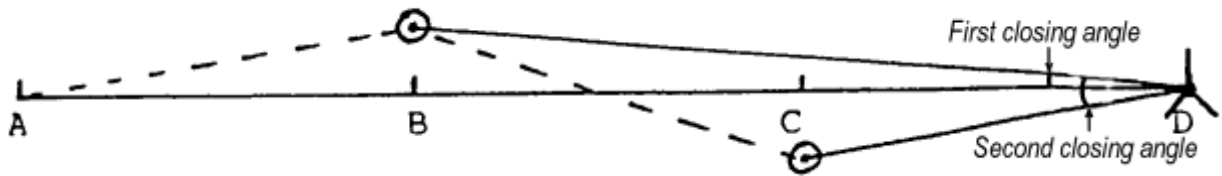

Figure Fourteen

If on arrival at the pinpoint abeam B, as shown in Figure Fourteen, we alter heading to fly to D, then the track we should now be flying along is the original track corrected for the first closing angle only. If on arrival at 'C' the pinpoint shows we are off track again, then the angular difference between the track we are now on (reciprocal of the radial from D), and the revised track we should have been on is the new (second) closing angle of our standard track correcting method. So we must alter heading by double the second closing angle.

USE OF RADIO AIDS DURING DIVERSIONS

If it becomes necessary to divert from our planned track for any reason and our new destination has a radio aid, our task is made a whole lot easier.

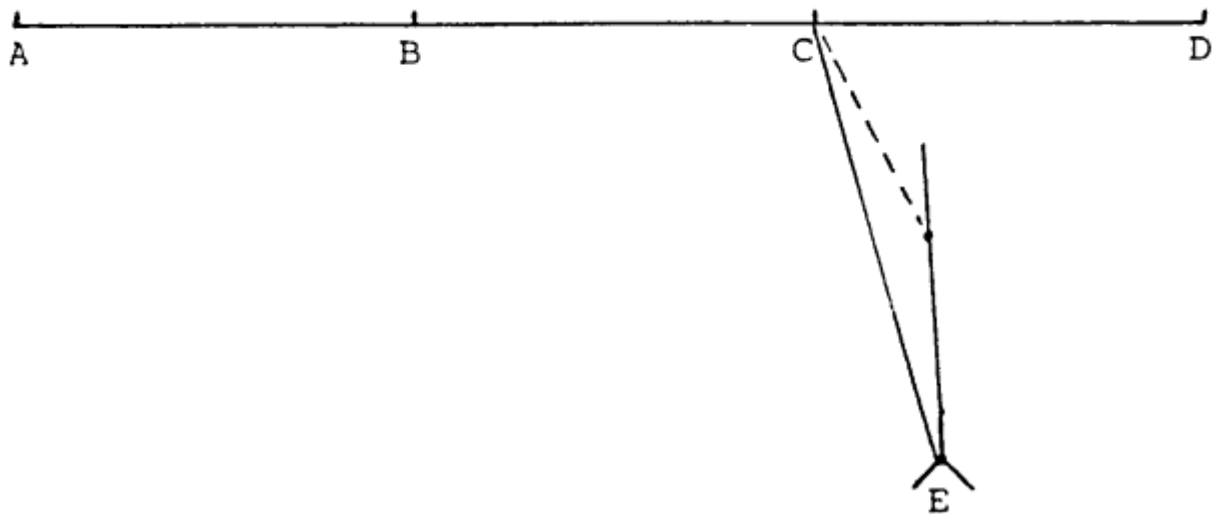

Figure Fifteen

In Figure Fifteen, it has become necessary to divert from C to E, and E has a radio aid which provides radials. The track to E is the reciprocal of the radial we are on from E, so we simply turn and head along this track. We are probably unaware of the drift so we simply maintain this heading until half way to E (by time estimate). At this half way point we note the new track to E. The angular difference between this track and the original track is our closing angle. Since we are about half way, we double the closing angle to obtain our heading correction. What could be easier?

USE OF RADIO AIDS WHEN LOST

Radio aids are particularly useful when lost. If we become lost we should immediately adopt the standard procedure and calculate a most probable position. If we are near a prominent feature we should stay near this feature whilst employing our radio aids to refine the accuracy of our position and identify the feature.

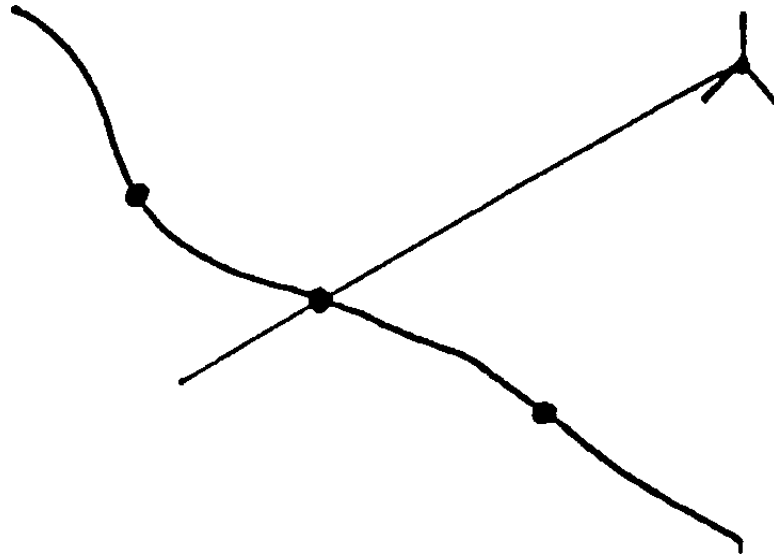

Figure Sixteen

In Figure Sixteen the pilot of our lost aircraft has calculated that he is within a particular circle surrounding his MPP in which he has found a minor road with 3 tiny towns on it. By tuning in to a nearby radio aid, ascertaining his radial from it and plotting this radial on the map he will have a two position line fix on his position. If there are two radio aids nearby, and he has two receivers in the cockpit he could obtain a third confirmatory position line (Figure Seventeen).

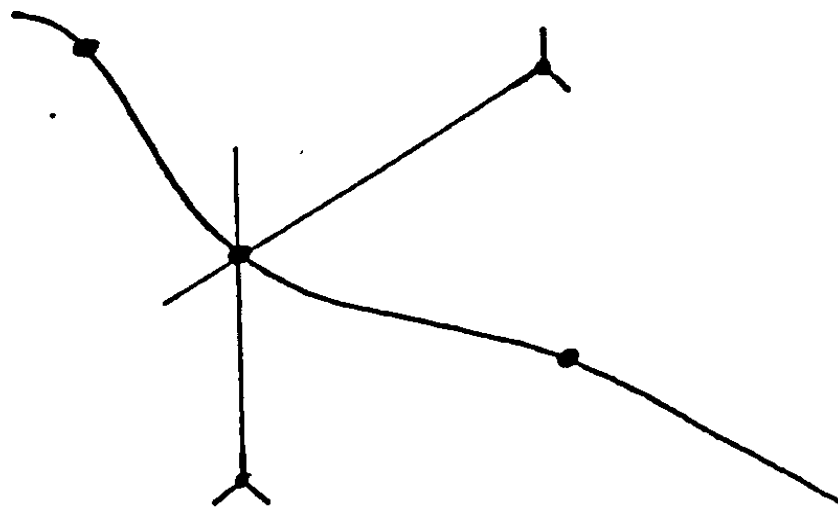

Figure Seventeen

Even with only one receiver the pilot could tune to each station in turn and plot the radials. As long as he remains near the feature whilst doing this the time difference between each plot is irrelevant.

Note that the position of the radio stations may not be plotted on your map because you didn't expect to get lost in this area in the first place. A quick 'eyeball' transposition from the 'Enroute Chart' to your map could be done, being aware that the radials plotted could be up to 10 degrees in error; or you could plot your radials on the enroute chart and transpose the final position to your map. Either method has small errors, but when combined with map reading they will be sufficiently accurate to get 'un-lost' and start navigating again.

The moral of this is: always have your planned track marked on the enroute chart and have it folded and handy to use. (Note: many countries have the radio aid locations and controlled airspace boundaries printed on the navigational maps, making this whole process much easier.)

Another interesting thing about being lost is that some pilots have gotten themselves so hopelessly lost that they can't even calculate a most probable position! In this case the radio navigation aids in the area become the sole means of navigation. A pilot who is this lost should climb as high as possible and tune into the most powerful radio aids in the area (preferably a VOR station) and either plot his position from them or fly to one of them and recommence navigating from there. Preferably straight home and sign up for some more dual navigation lessons.

CONCLUSION

Radio Navigation Aids can be a most useful supplement to normal visual navigation procedures. Their correct use will ease the pilot navigator's burden but their incorrect use will only add to it. Remember, they will help you to navigate but they will not navigate for you. (Lesson 10 details some full radio navigation procedures which you may find useful when you gain some visual navigation experience and confidence.)

At **Annex A** I have detailed a standard method to tune and operate each of the radio aids mentioned.

At **Annex B** I give a simplified description of how these radio aid work and how reliable they are.

Annex A**TUNING AND OPERATION OF COCKPIT
RADIO NAVIGATION EQUIPMENT**

Here is a simple mnemonic to use when you decide to operate any of the types of radio navigation equipment mentioned in the main part of this lesson.

T	Tune
I	Identify
O	Orientate
P	Plot

The following details the actions required to use each of these radio navigation aids; they follow the foregoing ‘**TIOP**’ mnemonic.

DME

<u>Tune</u>	Turn the on/off switch ON and select required frequency (Channel number).
<u>Identify</u>	Listen to the Morse code transmission to ascertain that the letter identifiers match those of the required station.
<u>Orientate</u>	Read the distance indication.
<u>Plot</u>	Plot the arc of the circle corresponding to the distance indication, on your map - this ARC is your position line.

VOR

<u>Tune.</u>	Turn the on/off switch ON and select required frequency.
--------------	----------------------------------------------------------

Identify Listen to the Morse code identifier or the ATIS broadcast being transmitted to confirm you are 'locked on' to the correct station.

Orientate Rotate outer 'bezel' of the instrument with the 'OBS' knob until the 'Course Direction Indicator' (CDI) is centered and the 'FROM' indicator is showing. Read the radial from the station at the top of the bezel. When tracking to a VOR station, centre the CDI with the 'TO' indicator showing. Your track is at the top of the indicator. When using preplanned radials, set the planned radial at the top of the bezel and continue on heading until the CDI moves to the centre - when it is centered you are on the preplanned radial. Note: Some modern VOR's also have an electronic digital readout of your present radial or track in addition to the CDI.

Plot Plot the radial from the station on your map, allowing for variation - this is your position line.

ADF

Tune Turn the equipment ON and select 'ADF' function on selector switch, then tune to required frequency.

Identify Listen to the Morse code identifier or the ATIS broadcast to confirm the station identity.

Orientate Hold a steady heading and align the movable compass card on the ADF indicator with the directional gyro. Read your magnetic radial from the ADF card against the tail of the ADF needle, or your track to the station from the point of the needle.

Plot Plot the radial from the station on your map, allowing for variation - this is your position line.

Annex B

RADIO AIDS - PRINCIPLES OF OPERATION

The following are ‘non-electronic’ descriptions of the basic principles of operation of each of the radio aids mentioned in this lesson.

Distance Measuring Equipment (DME)

Imagine tossing a ball against a wall and catching it on the rebound. Imagine that the speed at which you tossed it remains constant throughout its travel, then depending upon your distance from the wall its time of travel will vary directly with this distance. If you don’t know your distance from the wall but know the speed of the ball, and can measure the time it takes to make the round trip, you can easily calculate the distance.

$$\text{Distance} = (\text{Speed} \times \text{Time}) \div 2$$

(We divide by ‘two’ because the time measured is the time for the ‘round’ trip, which is twice the distance from the wall.)

The DME unit in the cockpit transmits an electronic pulse to the ground station it is tuned to, and this ground station immediately returns the signal. The unit measures the time this round trip took (at the speed of light), calculates the distance using the forgoing formula, and displays it to the pilot on the cockpit instrument (either a dial or a digital display). The cockpit instrument can also display the aircraft’s ‘rate of closure’ with the ground station by recording the change of distance over a certain time. (More on how to use this feature in Lesson Ten.)

Imagine that a number of other ball players are also throwing balls against the wall from various distances. How do you determine that you are catching and measuring the trip time of your ball? Easy, each ball player uses a different coloured ball, so you only catch your ball.

The ground station is capable of responding to a large number of ‘users’ virtually simultaneously because the unit in the aircraft transmits each pulse with a different random code superimposed on it and will only measure the round trip time of the pulses which returns with that code. The unit does this several times before deciding it has the correct information thereby eliminating any chance that another unit has randomly transmitted the same sequence of codes.

Assuming that the aircraft's DME unit is serviceable and correctly calibrated the distance information obtained from this equipment is quite reliable and useable out to its maximum range. The two factors which determine this maximum range are the power of the transmitter and the altitude of the aircraft. DME is not affected by weather; however, the electrostatic discharge from thunderstorms (lightning) can momentarily interrupt its operation.

One final note on the accuracy of DME. If you were throwing the ball at the foot of the wall and it was bouncing back up to the level of your hand, its time of travel would be slightly longer than if you bounced it off a point on the wall at the same height as your hand. This is because the 'slant' distance to the foot of the wall would be slightly longer than the horizontal distance. This also applies to the DME distance displayed in the cockpit, and this distance will differ from the actual horizontal distance depending upon how high you are and how far from the ground station you are. If you flew directly over the ground station 6080ft above it, the DME would indicate 1nm. This difference between actual and slant range at the normal operating altitudes of light aircraft is not significant and need not be allowed for during the course of normal navigation.

Automatic Direction Finding (ADF)

The simplest analogy I can use for this device is your own ears. Because your ears are mounted on each side of your head and are orientated forward, you are able to determine from which direction a particular sound is coming by rotating your head until each ear hears the sound at the same strength. Whichever way your face is pointing is the direction from which the sound is coming. This directional orientation comes from your own senses and does not depend upon anything outside of you except of course that something has to be making a sound for you to be able to detect it in the first place. Also, since you can turn your head independent of which way the rest of your body is pointing (within reason), the direction from which the sound is coming is normally expressed relative to where your body is pointing at the time. For example, if you had to turn your head 90° to the right to locate the sound you would say that it was coming from your right, but if you then turned your body around you would say the sound was then coming from your left, and if you turned your body into line with the direction your head was pointing you would say the sound was coming from directly ahead. All of these directions are relative to your body's orientation and are independent of the world around you.

The ADF unit in the aircraft is similarly 'self sufficient' as long as something is broadcasting on the radio frequency to which it is tuned. This can be a purpose built Non Directional Beacon (NDB) or an ordinary AM radio station. NDBs have been erected to assist radio navigation by ADFs and are usually more powerful than local radio stations (but not always).

The ADF unit uses a combination of ‘loop’ and ‘sense’ antennas to determine the direction of the incoming radio signal, and displays the information on a circular dial (calibrated like a compass card) with a needle. Basically the needle ‘points’ toward the source of the signal independently of the direction the aeroplane is heading, which means that the cockpit display will indicate a bearing to the station relative to the heading of the aircraft. If the NDB is off to the right of the aeroplane the needle will point to the right. If the aeroplane is turned through 180° the NDB will now be on its left and the needle will point to the left. This bearing display is called a ‘Relative Bearing’. Figure Eighteen shows an ADF display with the station 60° to the right of the ‘nose’. The HDG (Heading) knob shown allows the pilot to manually rotate the card and, by aligning it with the aircraft’s direction indicator, convert relative bearing into magnetic bearing.



Figure Eighteen

On some instruments the ADF ‘needle’ is mounted on the direction indicator so that the needle and the direction indicator move together when the aircraft is turned. This instrument automatically displays the magnetic bearing of the station regardless of the aircraft’s heading; it is called a ‘Radio Magnetic Indicator’ (RMI). Figure Nineteen shows an RMI with two needles. From this diagram you can see that the aircraft’s heading is 324° and the magnetic bearing to the NDB is 290° . (The purpose of the ‘other’ needle will be discussed in a moment.)



Figure Nineteen

The ADF is subject to a number of errors in much the same way as your hearing can be tricked by echoes and reflections of the incoming sound waves. An ADF will only detect the direction from which the radio waves arrive at the antenna. These radio waves can be reflected from other objects (including the aircraft's own structure) and can be refracted by different layers of air within the atmosphere such as the different temperature of air over the sea compared with that over the land along a coast line. (This latter effect is called 'coastal refraction'.) All of these errors lead to unreliable bearing information, all of which means that the ADF is the least accurate and the least reliable of the three radio navigation aids we are discussing in this lesson.

In addition, thunderstorms can be big, powerful, broadband transmitters each time they discharge electrostatic energy by way of lightning. An ADF will prefer to point at these lightning discharges rather than the NDB to which it is tuned, making the information it is displaying to the pilot quite unreliable when ever thunderstorm are around, (which is usually when you need the information the most!) I guess the 'up side' of this is that the ADF will tell you in which direction the biggest meanest thunderstorm is, so that you can fly in the other direction.

VHF Omnidirectional Radio (VOR)

In the United Kingdom during the 1950's there existed devices called 'Voice Rotating Beacons'. They were ground based radio transmitters with rotating directional antennas synchronized with a tape recorder on which was the recording of a person's voice saying the antenna's direction every 10 degrees of rotation. A pilot simply had to tune into the frequency of one of these beacons and he would hear a voice saying a compass direction about once every minute ("010", or "020", or "030" etc). What he heard was his radial from that beacon. This was a very simple aid to navigation which only required a normal VHF transceiver in the aircraft. The radial information received did not depend upon which way the aircraft was heading, it was a simple statement of which radial the aircraft was on at that time. It is a pity such simple devices are not still around.

The concept of operation of the VOR is the same, except that the tape recorded voice has been replace by a coded electronic signal for each one degree of rotation of the antenna and the antenna rotates much faster. To receive these coded signals the aircraft has to be fitted with a special VOR receiver; the standard communication transceiver is no longer suitable.

The radial information received from a VOR can be displayed to the pilot by a needle on an RMI display (the 'other' needle on the preceding RMI diagram), by a digital readout of the radial, or by a device called a VOR indicator.

A VOR indicator is circular instrument with an outer ‘bezel’ calibrated like a direction indicator card, which can be rotated manually by the pilot via the ‘OBS’ knob (Omni-Bearing Selector) and set to any radial. The instrument compares this setting with the radial information being received from the VOR station and displays the difference between them by the displacement of the Course Deviation Indicator (CDI) which is a needle in the inner part of the instrument. The CDI, which pivots at its top end, will be centered if the radial the aircraft is on (or its reciprocal) coincides with the setting the pilot has made with the OBS. The ambiguity between the radial and its reciprocal is resolved by small arrows in the instrument pointing to either the word ‘TO’ or the word ‘FROM’. If ‘FROM’ is indicated the number at the top of the bezel is the radial, if ‘TO’ is indicated it is the reciprocal and would be the track ‘TO’ the transmitter site. Figure Twenty (a) shows a VOR indicator with the bezel set to 360°, the CDI centered and ‘TO’ indicated, which means that the aircraft is on the 180° radial from the VOR site and should track 360°M to get ‘TO’ the site. Figure Twenty (b) shows the CDI bar giving a ‘fly left’ indication because the aircraft is 5° to the right of the track selected on the bezel. (Each ‘dot’ represents 2°.)

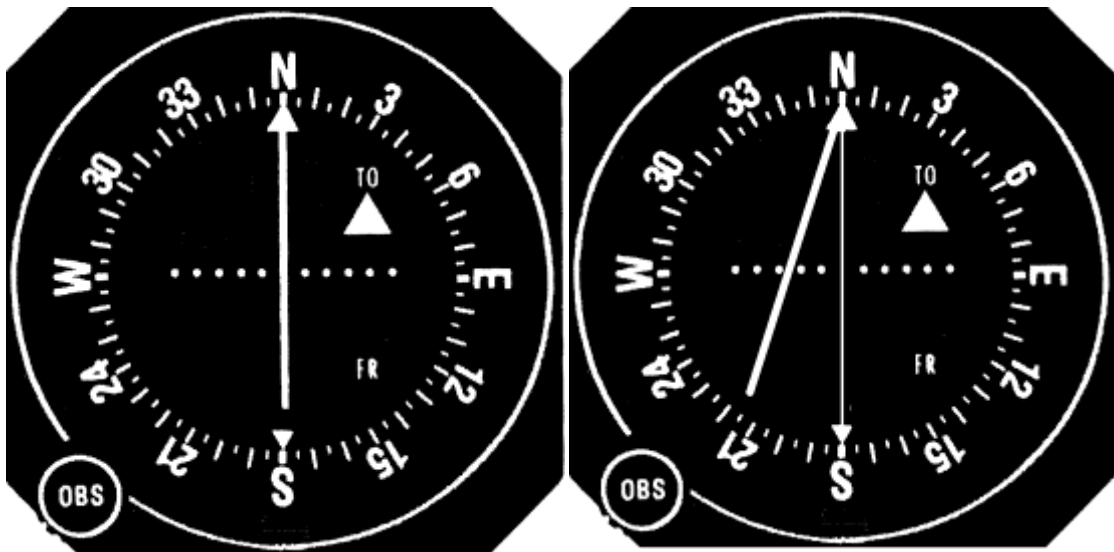

Figure Twenty (a)

Figure Twenty (b)

The RMI display is better for general orientation whilst the VOR indicator display is more accurate when tracking directly TO or away FROM the VOR ‘beacon’. There will be more on the technique of ‘area navigating’ by the use of these instruments in Lesson Ten.

VOR beacons usually have quite powerful transmitters, and because of the digital nature of the signal, are not affected as much by bad weather or thunderstorms; however, the signal can be distorted by reflection and refraction from terrain (called ‘scalping’). The range at which the VOR signal can be received depends upon terrain and the aircraft’s altitude. The VOR is the most accurate and reliable of the radio navigation aids discussed in this lesson.

LESSON TEN

AREA NAVIGATION USING ONLY RADIO AIDS

The term ‘Area Navigation’ means being able to fly all over the sky randomly and know where you are at all times. Doing this whilst visual with the ground is not too difficult but doing it above cloud or in conditions of poor visibility (like ‘in’ cloud) or at night is a bit trickier.

Most ‘airliners’, when flying in cloud, fly along designated tracks to and from radio beacons within published air routes (they do it when the sky is clear too). When flying out of range of these radio aids some other means of navigation is needed. Back in the days of long range piston engine airliners like the Lockheed Super Constellation, this was achieved by a navigator trained in celestial navigation doing a lot of ‘plotting’ on a chart. Then at about the time of the introduction of the Jet Airliner, the ‘Inertial Navigation System’ (INS) was introduced, which virtually ‘did’ the navigator out of a job. Inertial Navigation systems rely on no outside reference at all, and because of this, are particularly useful for military application. They are also very expensive pieces of kit so are not normally found in light aeroplanes. About 20 years ago another system called the Global Positioning System (GPS) came upon the ‘scene’ and has developed into a highly accurate and affordable navigation system available to all for just a few hundred dollars. Inertial and GPS systems allow aviators to fly all over the sky and know where they are at all times; however, most pilots only use them to fly to or from ‘way points’ just like the ‘good old days’ thereby wasting a lot of their potential.

Now from what I have said so far you would think that area navigation without reference to the ground has only become possible with the advent of Inertial and GPS navigation systems. Not so! During the Vietnam War a Forward Air Controller (FAC) could summon a strike aircraft to his location by simply broadcasting his position as a radial and distance from a TACAN beacon, (*“This is ‘Hot Shot One’ on the two three zero radial, two zero miles from channel fifty one, I have a target and I need some heavy ordnance.....anyone interested?”* *“Roger hot shot one this is ‘Skunk 52’ coming your way with six 750 high drags, be with you in 8 minutes”*). The strike aircraft would fly directly to the FAC from its TACAN position, the pilot taking no more than 5 seconds to work out the heading to steer and distance/time to run, in his head! ‘TACAN’ stands for **TACTical Air Navigation** and is essentially an integrated VOR and DME system relying on a beacon located on the ground. TACAN equipped aircraft were able to fly from ‘point to point’ without the use of preset waypoints or any other means of area navigation provided the pilot knew the correct technique (and all those guys did).

Back in the late 1960's I was checked out on the RAAF's new jet trainer, the Macchi MB326H. This neat little aeroplane was fitted with TACAN, and the information from the TACAN was fed into a HSI, (Horizontal Situation Indicator). When I first saw this device I thought it was a nightmare, but after 30 minutes of instruction in its use (in cloud) I wondered how I had ever survived without it.

The techniques taught to me enabled me to fly all over the sky in or above cloud and know where I was at all times (within the range of the TACAN beacon of course). A few years later I found myself once again flying an aeroplane without TACAN or a HSI, but it did have DME, it also had ADF and VOR feeding through an RMI. I found that using this 'point to point' technique was still possible using the information provided by these simpler instruments.

Many years later when the Sydney Aerobatic School expanded into a fully fledged 'Flying School' I found that this area navigation technique came in handy for teaching night navigation, where the ability to orientate oneself by the use of radio aids is essential.

What follows are descriptions of the methods I used to 'area navigate' using the basic radio navigation aids still found in a large percentage of light aeroplanes. Whilst all of these radio aids will ultimately go the way of the 'voice rotating beacon', and GPS will become the principle radio navigation aid, some aviators may still find these techniques useful, particularly in conditions of 'reduced' visibility. (Indeed they can be used on a GPS/RMI display or GPS/MAP display without having to continually insert way point data.)

Using DME to track TO or FROM an aid.

This is not quite area navigation but will give you an idea of how, with a little thought, you can extract information from a radio aid which may have never occurred to you before.

I explained in Annex B to Lesson Nine that most DME indicators also display the 'rate of closure' with the beacon. Now this is sometimes erroneously displayed as 'ground speed' and can mislead an untrained pilot. Rate of closure will only be the aircraft's ground speed when the aircraft is heading directly to or from the beacon. Note I said heading, not track. Study Figure One for a moment. Aircraft A, when heading toward the beacon, has a rate of closure equal to its ground speed, but if it is passing the beacon obliquely its rate of closure is considerably less than its ground speed and will diminish to zero as it passes abeam the beacon.

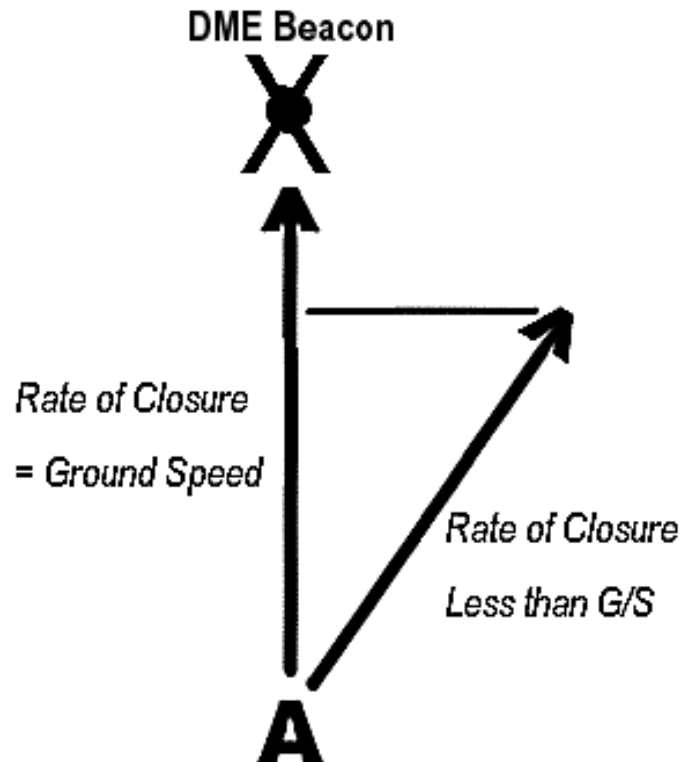

Figure One

How do we use this information to determine the correct heading to the beacon? Once the DME beacon is tuned and identified the aeroplane is slowly turned (about rate one) in either direction whilst watching the rate of closure indication. If it starts to reduce reverse the direction of the turn, then note the heading you are passing as the rate of closure 'peaks'. This is the heading to or away from the beacon. Steer this heading and the distance will either increase or decrease. If it increases turn onto the reciprocal heading, because you are going the wrong way! Hold this heading until half way to the beacon then repeat the process. If you note that the new heading to the beacon is different to the original then correct your heading to steer by double this difference. (Sound familiar?) Which way do you turn? Either way, and then watch the rate of closure; it should increase slightly if you have turned the correct way; if it decreases, turn the other way. This heading will now take you to the beacon. This process is called DME homing, and is a dying art.

Using ADF or VOR to determine distance.

This technique has elements of area navigation in it and can be quite useful when transiting past a radio aid to check your distance abeam. It is called the "45° radial change method". All you have to do is note the time when you pass a radial from the beacon which is 45° to your track, and then note the time when you pass the radial at 90° to it. The time interval between these two transits

multiplied by your ground speed is your distance traveled and is also your distance from the station when directly abeam. Figure Two illustrates.

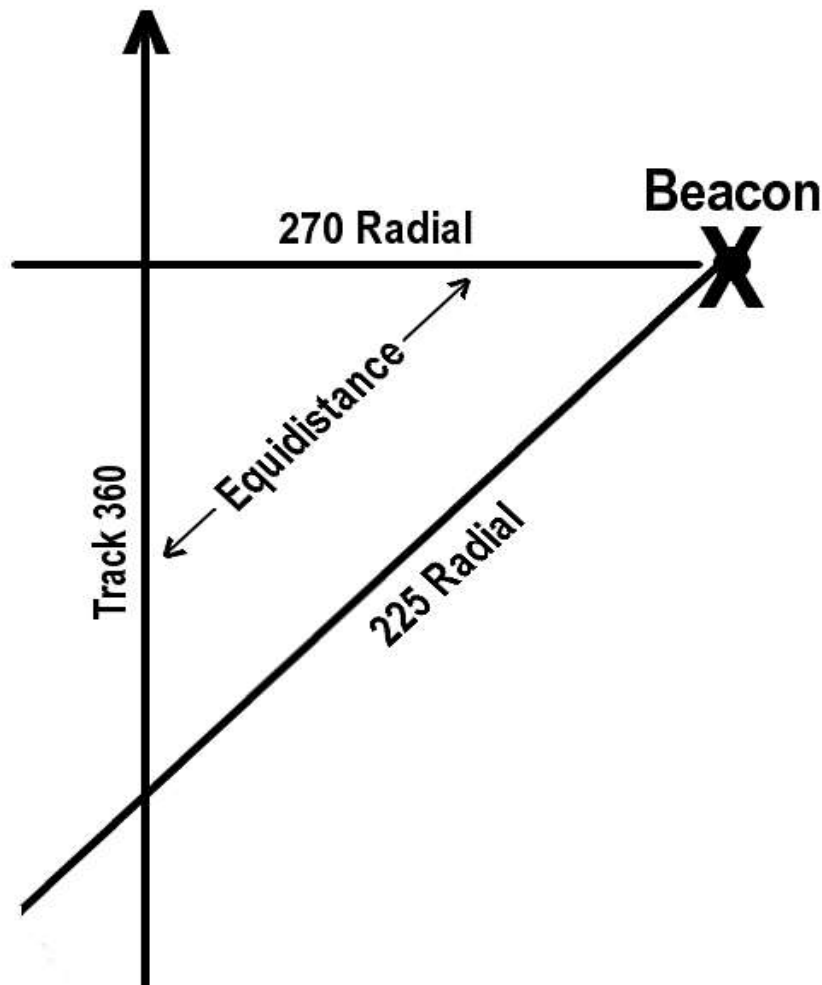

Figure Two

High speed aircraft can use a variation of this method for a quick distance assessment; this is called the “10° radial change method”. The method is: Note the time interval in seconds between transiting a radial 10° ahead of abeam to the radial dead abeam, divide the time interval by ten and multiply by your Mach number. This is your distance from the beacon!

Point to Point Technique

This is the technique the strike fighter pilot used to find the FAC, and you can use to ‘area navigate’ within the area covered by the radio aid you are tuned to.

Imagine for a moment that you are a Radar controller sitting in front of your Radar screen and directing two aircraft (**X1** and **X2**) from their present locations to different locations. **X1** is to go to ‘**O**’ and **X2** is to go to ‘**C**’ as shown in Figure Three.

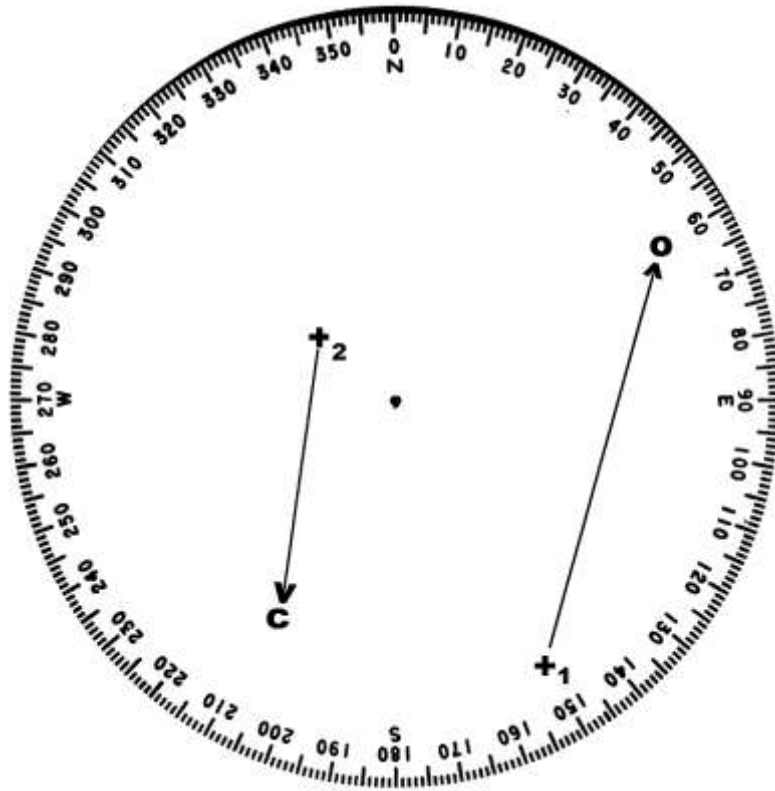

Figure Three (Radar Screen.)

Aircraft **X1** will have to steer 015° to get to 'O', whilst aircraft **X2** will have to steer 188° to get to 'C'. How did I work that out? Check out Figure Four.

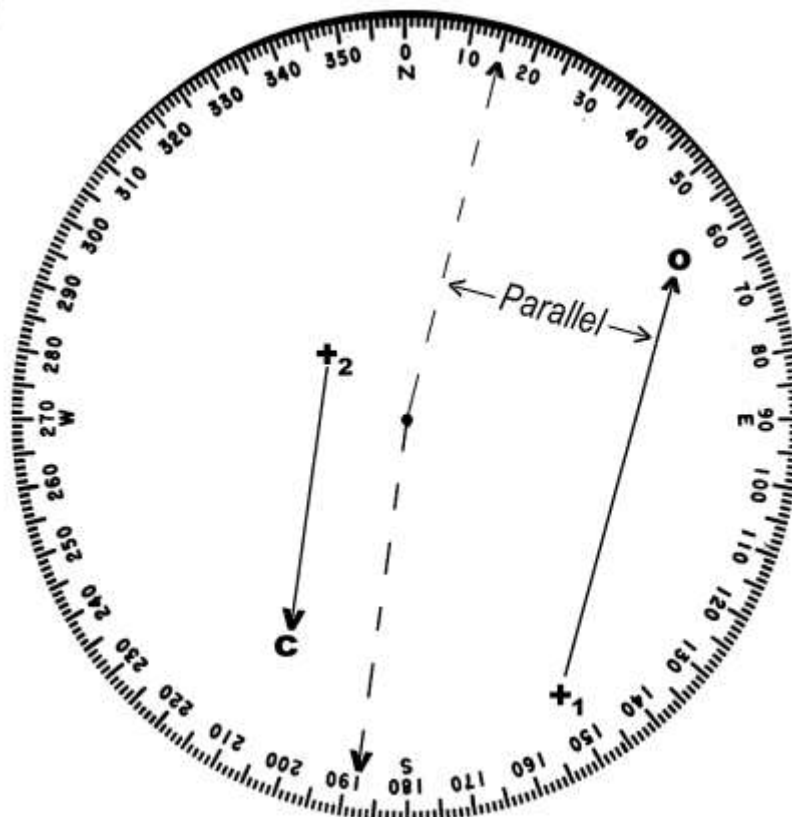

Figure Four (Radar Screen.)

You can see that all I did was imagine a line parallel to the required track emanating from the centre (the radar site) to the edge of the screen and read off the heading from the compass scale.

Now most times when being taught to read an ADF or VOR the pilot imagines that he is at the centre of the RMI or ADF card and that the needle is pointing to where the beacon is (Figure 5a). I want you to reverse that thinking by imagining that the RMI is a radar screen and imagine that you, the radar controller, are at the centre of the instrument directing you, the pilot, who is at the **tail** of the needle on the radial from the beacon as indicated. To make this easier to imagine we are, from now on, going to ignore the pointy end of the needle completely (Figure 5b) and imagine that our aeroplane (**x**) is at the tail of the needle.



Figure 5a



Figure 5b

You can see from Figure 5b that the aeroplane is on the 150° radial from the beacon (just like aircraft **X1** on the radar screen). If your aircraft is not fitted with an RMI then it will be necessary to manually rotate the ADF card to match the direction indicator to achieve this picture, (indeed I have found many pilots prefer to use the ADF card because the RMI is cluttered with a little picture of an aeroplane and other stuff we are trying to ignore). If you are using VOR and only have a VOR indicator and no RMI, no problem, rotate the bezel with the OBS and centre the CDI with the little arrow pointing at FROM and read the number at the top. This is your radial from the beacon; now imagine '**x**' at that radial on the direction indicator.

If we now want to fly to point '**o**', on the 060° radial on our mini radar screen (Figure 6a) all we have to do is imagine a line from '**x**' to '**o**' as in Figure 6b.



Figure 6a



Figure 6b

And then just like the Radar controller, parallel this line with another imagined line through the centre and read off the heading of 015° at the edge as in Figure 7a. Finally turn your aeroplane onto that heading as in Figure 7b.

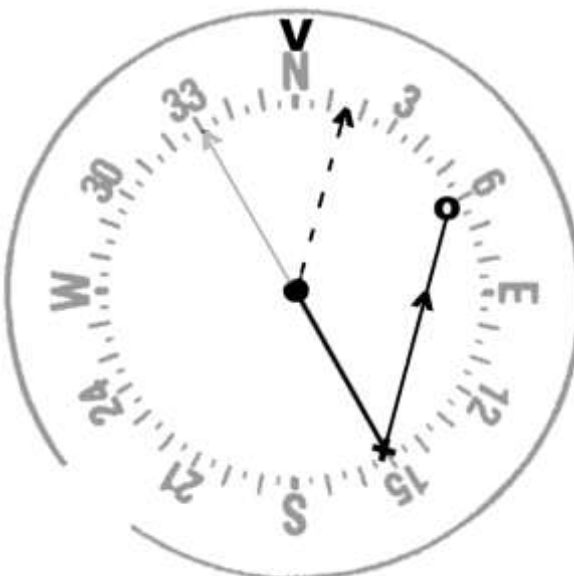

Figure 7a

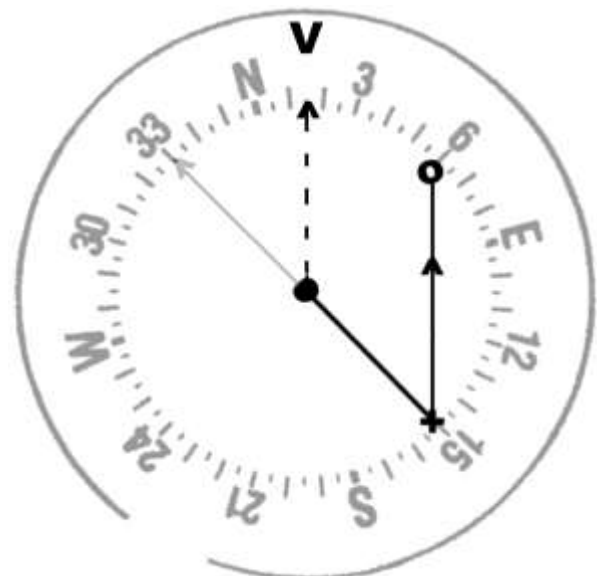

Figure 7b

All you now do is steer 015° until the tail of the needle swings around to 060° and you are there. If you are using a VOR indicator, set the bezel to 060° and wait for the CDI to swing to the centre. When you get there you can decide whether to turn right and track the radial outbound, which would be a heading of 060°, or turn left and track inbound on the reciprocal, which would be a heading of 240°, or you can go through the whole process again and go somewhere else.

If you have decided to turn left and track the radial inbound you may feel that the 'intercept' angle upon arrival at 'o' is too great and you would prefer a lesser

angle. No problem. When passing a convenient radial on the way to 'O', redo the whole thing. In Figure 8a, upon passing the 090° radial we reassess a new heading, which in this case would be 348°, and turn onto it as shown in Figure 8b. This will now give you an intercept angle of about 90°. Again, if using a VOR indicator initially set the bezel with the OBS to 090° and wait till the CDI centers to indicate that you are passing the 090° radial.



Figure 8a



Figure 8b

So, once again, when the tail of the needle gets to the 060° radial or the CDI centers (Figure 9a) turn onto a heading of 240° to head inbound to the beacon (Figure 9b). Depending upon the distance from the beacon and the speed of the aircraft, you may have to 'lead' the radial by a couple of degrees to allow for the aircraft's turn radius, (ie start turning when passing the 062° radial).



Figure 9a



Figure 9b

Now in this example we haven't worried about distance from the beacon (although if you are really 'with it' you can also time a 45° radial change on the way to 'O'); our track basically gets us to 'O' at the same distance we were from the beacon when we were on the 150° radial. But, if we also have DME, we can *really* 'area navigate' using this 'point to point' technique. Let's work through another example using DME too.

Imagine that you are that strike fighter pilot who hears the call from the FAC described in the introduction. You glance at your TACAN (RMI/DME) and note that you are on the 150° radial at 40 miles (you are steering 030° too but that is irrelevant) and you note the FAC is on the 230° radial at 20 miles. You use your DME distance to establish the scale of your mini radar screen, which means that you are at the edge of a 40 mile radius circle and the FAC is at 'O', half way out from the centre on his radial (Figure 10a). Then 'eyeball' a line from your position to the FAC, parallel it from the centre to the compass scale at the edge. Your heading to the FAC is 300°. Now 'eyeball' the length of the track to get there and compare it to your scale and you can see that, in this case, it is about equal to your DME distance from the beacon, and since you can only make 300kt hauling all of those bombs (5 miles a minute) you tell him you will be there in 8 minutes (Figure 10b).



Figure 10a

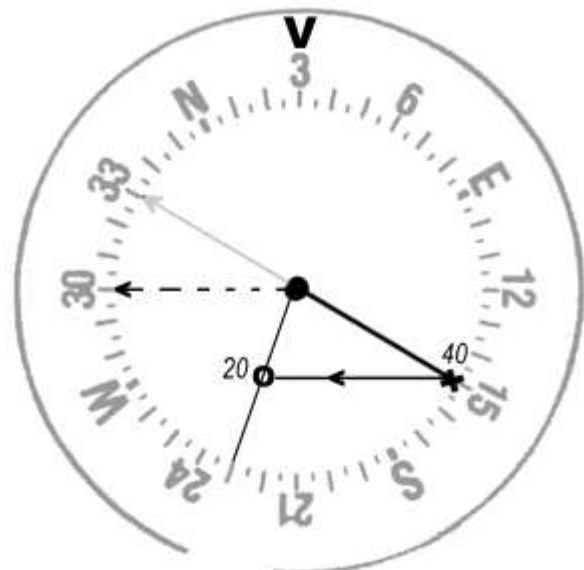

Figure 10b

Once you are on your way to your target (Figure 11a) and have progressed to passing say, the 190° radial, you can reassess the whole thing from this new position as a new 'point to point' problem and fine tune your heading and time assessment accordingly (Figure 11b). In this case no change is necessary, so arm your bombs, you are about to ruin somebody's day.

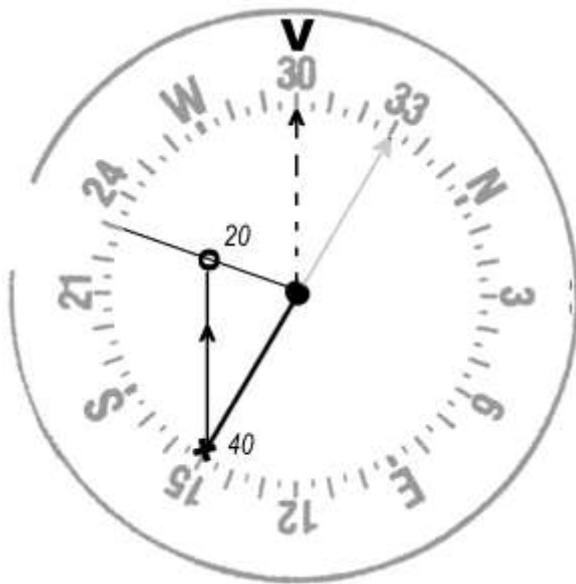

Figure 11a

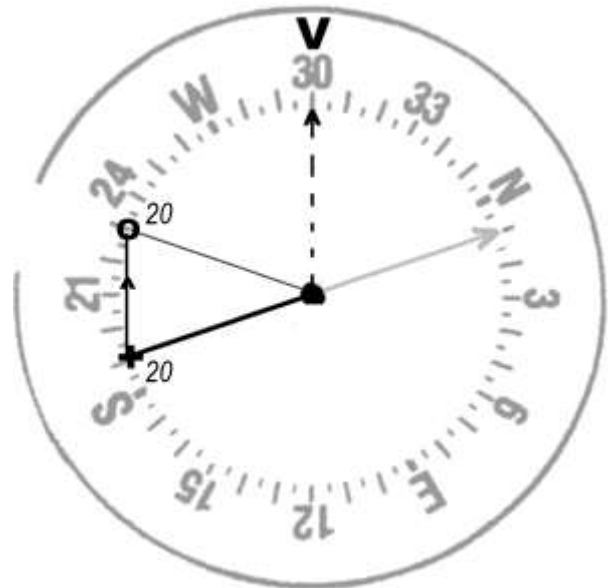

Figure 11b

What if you were closer to the beacon than the FAC? Let's work the problem as if you were only 10 miles DME. The greater of the two distances sets the scale of our mini radar, so it is now only 20 miles radius and it is you who are only half way out from the centre. So imagine you are half way along the tail of the needle and the FAC is at the edge (Figure 12a). Apart from this shift in perspective the rest is worked out the same way.



Figure 12a

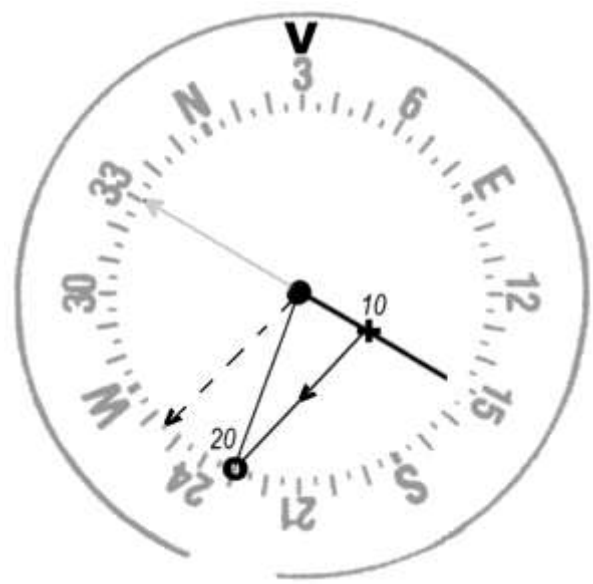

Figure 12b

As you can see from figure 12b, the heading to steer is now 255° and, in this case, the distance to run is 20 miles and the time interval is 4 minutes. After proceeding on a heading of 255° (Figure 13a) and once again crossing the 190° radial (Figure 13b), the whole thing can be reassessed and fine tuned.



Figure 13a



Figure 13b

Earlier I made the comment that the heading you are on whilst working out the ‘problem’ is irrelevant. I would just like to emphasize that point again in case you missed it. Compare Figure 10b to Figure 11a or Figure 12b to 13a, and you will see that whilst the aircraft is on different headings the ‘radar’ picture is the same; it is only its orientation that is different. Indeed, look at any of the preceding figures and rotate the page to put any heading at the top and nothing about this ‘point to point’ method changes except its orientation. But remember, if you are using an ADF card to work the ‘problem’ it MUST be set to the current heading or the radial information will be incorrect and who knows where you will end up!

As a general aviation pilot you won’t be dropping bombs under the direction of a forward air controller, but this technique will get you from anywhere to anywhere within the coverage of your radio aids for whatever the reason. Obviously I have chosen some easy distances for the purposes of illustrating the principle of this technique. Some distance scales will take a little more imagination but will become easier with practice.

Now I am not a great believer in these home computer flight simulators; however, they can be used quite effectively to practice this ‘point to point’ radio navigation technique in the comfort of your own home until the ‘cows come home’.

If you do not have one of these computer flight simulator games, I have attached, as the back page to this lesson, six blank ‘mini radar screens’ of about actual size. Copy it as many times as you wish, and with a pencil and a brain work some problems for yourself. You will be amazed at how quick and accurate you will become...enjoy....learn.

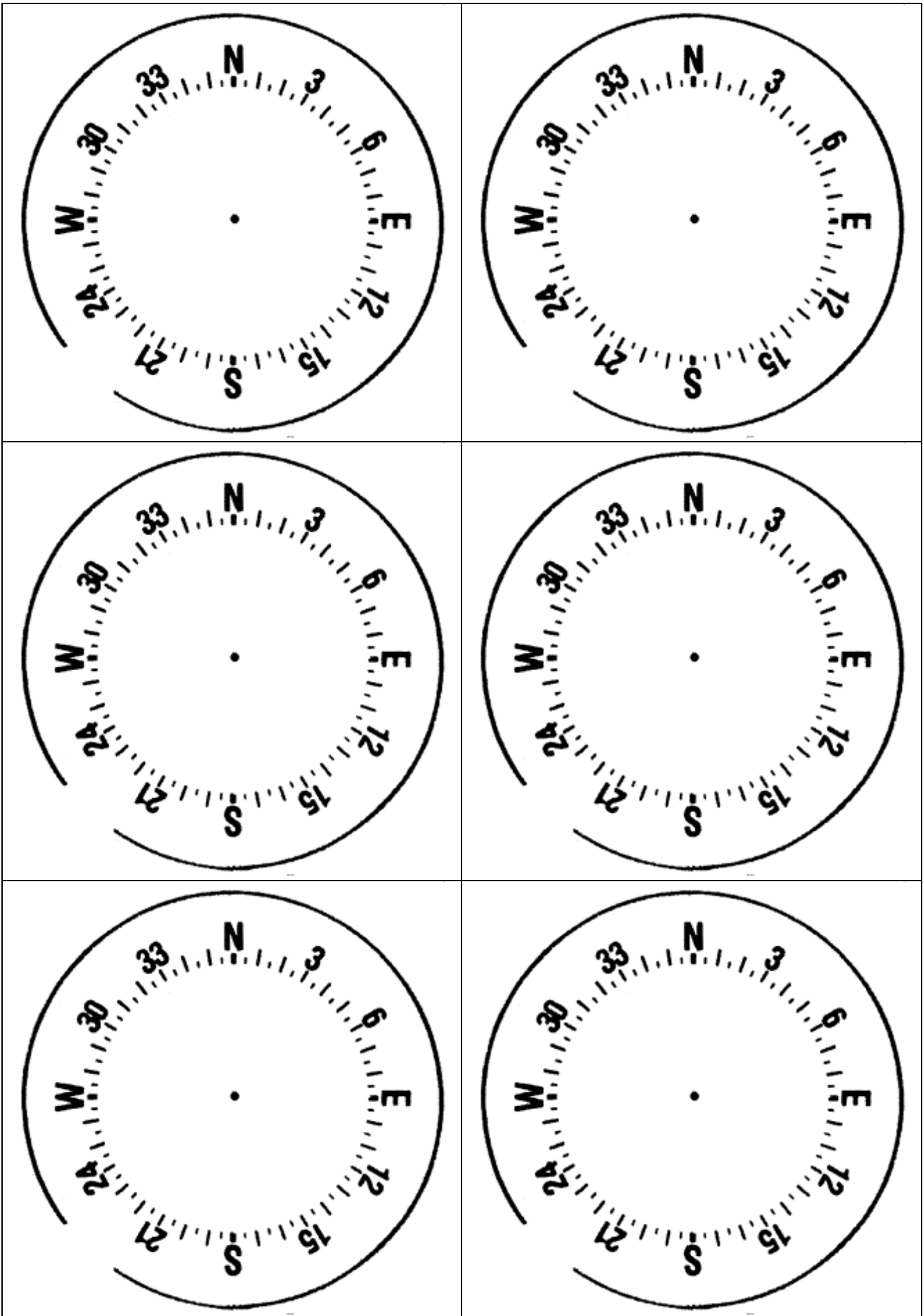

POST SCRIPT

So there they are; simple techniques for keeping ourselves tracking toward our destination and updating our estimate of the time we are going to get there. But I must emphasize once again that, with the exception of Lesson Ten, these are not ‘navigation’ as such. They are techniques which ‘fine tune’ navigation; they just contribute to the final outcome. The major part of successful navigation is accurate pre-flight planning and accurate flying, and the test of how well you do that is how little you have to use the techniques I have taught you here. If you find that your flying accuracy is being degraded by the amount of effort you are putting into using these techniques, stop, relax, you are ‘over working’ the problem. Remember the first Golden Rule: Aviate – Navigate – Communicate.

There are other techniques which can be used to aid visual navigation, such as ‘air plotting’, flying ‘wind drift triangles’ to determine wind velocity using a ‘drift sight’, or using wind lanes and wave height to assess wind velocity when flying at low level over water. But I have not detailed them here because they are virtually a lost art. But to illustrate what is possible I should mention one of Aviations most famous aerial navigators, Sir Francis Chichester, from whom I stole the quotation at the beginning of this book. Frank (before he was a ‘Sir’) navigated solo from New Zealand to Australia across the Tasman Sea via Norfolk Island and Lord Howe Island in 1931 in a DeHavilland ‘Gipsy Moth’ float plane using a marine sextant to fix his position and making the ‘sight reduction’ calculations on a knee pad and tapping out position reports in Morse code every hour with a telegraph key strapped to his other leg. All in an open cockpit! He then continued on, using similar techniques, all the way to Japan. Later in life Sir Francis became the first person to sail single handed around the world in a sail boat he named “Gipsy Moth III”. (He was 60 years young.)

My last operational flight with the Royal Australian Air Force, was to fly a Caribou, which had been on duty in Kashmir with the United Nations, from Islamabad (Pakistan) to Sydney (Australia). The flight was made at an average altitude of 7000ft at a true airspeed of 140kts. It was an odyssey which lasted many days. Along the way we had to use all of the ‘fine tuning’ techniques detailed in this book and a few others, including a ‘point to point’ radio aid diversion around Bangladesh airspace over the Gulf of Bengal whilst enroute from Calcutta to Rangoon. Apparently our diplomatic clearance had been ‘lost’!

The leg across the Timor Sea from Bali (Indonesia) to Broome (North West Australia) was accomplished at low level with the aid of a ‘drift sight’, whilst the two day crossing of Australia from Broome to Sydney, across the ‘red center’, demanded strict track correcting techniques as detailed in this book. It all worked. It was a very satisfying end to that part of my flying career.

However, my most memorable ‘cross country’ flight occurred many years prior to this, quite early in my Air Force career. I had been a fighter pilot for only about 12 months and I had been tasked this day to lead a pair of Sabres from Darwin to our home base at Williamtown (in Newcastle, north of Sydney). The flight required us to stage through Townsville, (North Queensland) to refuel.

As fate would have it, my wing man’s aeroplane became unserviceable at engine start, so we were both delayed till mid afternoon. We eventually arrived in Townsville just before sunset and after a one hour ‘turn around’ departed for the 1000 mile, 2 hour flight to ‘Willy’, in the dark. After leveling at 40,000ft initial cruise altitude I discovered the little light in my ADF frequency selector was not working, so dialing frequencies with one hand whilst holding a torch in the other and flying with the third presented some difficulty, especially since I had to fly smoothly as my wing man was only a few meters away. I set the ADF frequency to ‘Willy’ (for future reference) and settled down to fly smoothly and accurately and let the ‘basics of navigation’ do the job. Not long after reaching cruise altitude the few lights of the world below vanished under a solid layer of cloud, but at that altitude the stars on this moonless night were brilliant. I felt like an astronaut in low earth orbit, but with a much better view thanks to the Sabres great ‘bubble’ canopy.

At that stage of my life I was unaware of celestial navigation techniques but I did know how to find South by reference to the Southern Cross star constellation and the pointer stars, and there it was, straight ahead. For the next hour I ‘orbited’ the dark Earth steering only by these stars as we slowly drifted up to about 43,000ft (as the drop tanks emptied). It was a most amazing feeling. Then a very large glow slowly floated past beneath my left wingtip. It was the lights of the city of Brisbane, lighting up the clouds from below. Whilst it was an intrusion into my ‘astronaut world’, it was also the only checkpoint I had had on the whole flight. So at least I knew I was orbiting in the right direction.

A half hour later it was time to leave ‘orbit’ and start down to the ‘real’ world. The ADF had finally found the ‘Willy’ NDB so down we went. We entered the clouds at 20,000ft and, a short time later, broke out at 500ft on a one mile final approach to land. It was raining and we had a 20kt crosswind.....welcome home.

Later that night, as I drifted off to sleep, I returned to that ‘place’ I had found among the stars. I have revisited it a thousand times since, in my head, but never again have I experienced such a perfect flight on such a perfect night.

Like I said at the beginning of this book, “often it is the journey not the destination”.

Supplement

The Navigation Game

The Navigation Game is designed to assist student navigators to practice the ‘Track Correcting’ and ETA updating techniques detailed in this book. The gamer will need a map, a navigation log, and an ordinary ‘dice’.

1. A suitable track approximately 60nm long should be drawn on the map and two equally spaced ‘check points’ should be marked on this track (1/3rd and 2/3rd points).
2. The navigation log should be prepared with the heading and time intervals for this track and distance. You may assume any groundspeed you like, but 2nm/min (120kts) makes for easy mental arithmetic.
3. The ‘flight’ can now commence. Nominate a departure time and record it in the ATD ‘box’, then record the ETA1 at destination on the navigation log and the ETA at the first check point (point B) on the map.
4. We are now approaching the first check point, roll the dice and note the number that it presents. Mark a pinpoint abeam the first check point based upon the distance off track indicated in the following table:

Number	Track Error.
1	One nautical mile LEFT of track
2	Two nautical miles LEFT of track
3	Three nautical miles LEFT of track
4	One nautical mile RIGHT of track
5	Two nautical miles RIGHT of track
6	Three nautical miles RIGHT of track

5. Roll the dice again and note the number that it presents, correct the arrival time at the first check point by the time indicated in the following table:

Number	Time Error.
1	One minute LATE
2	Two minutes LATE
3	Three minutes LATE
4	One minute EARLY
5	Two minutes EARLY
6	Three minutes EARLY

6. Based upon these ‘dice generated’ track and time errors, apply the track and ETA correcting techniques detailed in this book and record the results in the navigation log and on the map as applicable.

7. We are now approaching the second check point, (point C) roll the dice and mark a pinpoint abeam the second check point based upon the distance off track indicated in the following table:

Number	Track Error.
1	Half nautical mile LEFT of track
2	One nautical mile LEFT of track
3	One & a Half nautical miles LEFT of track
4	Half nautical mile RIGHT of track
5	One nautical mile RIGHT of track
6	One & a Half nautical miles RIGHT of track

8. Roll the dice again and correct the arrival time at the second check point by the time indicated in the following table:

Number	Time Error.
1	Half minute LATE
2	One minute LATE
3	One & a Half minutes LATE
4	Half minute EARLY
5	One minute EARLY
6	One & a Half minutes EARLY

9. Based upon these ‘dice generated’ track and time errors, apply the track and ETA correcting techniques again and record the results in the navigation log.

10. We are now arriving at the way point (point D), record the ATA. Draw another track on the map and do it all again.

This simple game will exercise your understanding of the track and ETA correcting techniques involved in this navigation system, and the random numbers generated by the dice will exercise your mental arithmetic too. Play it often, and you will find the same number combinations and ‘sums’ reoccur regularly, and very soon the ‘answers’ will just ‘pop’ into your head easily.

I suggest that you play this game on each of your actual training navigation exercises too, once you have prepared your maps, prior to the flight. Study the area surrounding each game pinpoint, as this will also help familiarize you with the actual terrain you will be flying over. (Use a soft pencil to mark the pinpoints etc, so that they can be erased before the actual flight.)